

AITC TECHNICAL NOTE 18

EVALUATION OF CHECKS IN STRUCTURAL GLUED LAMINATED TIMBERS

April 2011

AMERICAN INSTITUTE OF TIMBER CONSTRUCTION

7012 S. Revere Parkway, Suite 140, Centennial, CO 80112

Phone 303-792-9559 • Fax 303-792-0669

Email: info@aitc-glulam.org • Website: www.aitc-glulam.org

INTRODUCTION

As discussed in AITC Technical Note 11, *Checking in Glued Laminated Timber* (1), checks in wood are separations along the fibers resulting from stresses developed during drying, with the effect being most prevalent if drying is rapid. Wood adjusts to an equilibrium moisture content in balance with the humidity of the surrounding atmosphere. The equilibrium moisture content (EMC) varies with the temperature and relative humidity of the surrounding air with relative humidity having the greatest effect. The EMC of wood at varying relative humidities and temperatures is given in **Table 1**.

In glued laminated timber, the individual laminations are dried prior to gluing so that the finished member more closely approximates the equilibrium moisture content expected in service. This reduces checking in glued laminated timber.

Table 1. *Equilibrium moisture content (%) based on temperature and relative humidity.*

Temperature		Relative Humidity																		
°C	°F	5%	10%	15%	20%	25%	30%	35%	40%	45%	50%	55%	60%	65%	70%	75%	80%	85%	90%	95%
-1.1	30	1.5	2.5	3.5	4.5	5.5	6.5	7.0	8.0	8.5	9.5	10.5	11.5	12.5	13.5	15.0	16.5	18.5	21.0	24.5
4.4	40	1.5	2.5	3.5	4.5	5.5	6.5	7.0	8.0	8.5	9.5	10.5	11.5	12.5	13.5	15.0	16.5	18.5	21.0	24.5
10.0	50	1.5	2.5	3.5	4.5	5.5	6.5	7.0	8.0	8.5	9.5	10.5	11.0	12.5	13.5	15.0	16.5	18.5	21.0	24.5
15.6	60	1.5	2.5	3.5	4.5	5.5	6.5	7.0	8.0	8.5	9.5	10.0	11.0	12.0	13.5	14.5	16.0	18.0	20.5	24.0
21.1	70	1.5	2.5	3.5	4.5	5.5	6.0	7.0	7.5	8.5	9.0	10.0	11.0	12.0	13.0	14.5	16.0	18.0	20.5	24.0
26.7	80	1.5	2.5	3.5	4.5	5.5	6.0	7.0	7.5	8.5	9.0	10.0	11.0	12.0	13.0	14.0	15.5	17.5	20.0	23.5
32.2	90	1.0	2.5	3.5	4.5	5.0	6.0	6.5	7.5	8.0	9.0	9.5	10.5	11.5	12.5	14.0	15.5	17.5	20.0	23.5
37.8	100	1.0	2.5	3.5	4.0	5.0	6.0	6.5	7.0	8.0	8.5	9.5	10.5	11.0	12.5	13.5	15.0	17.0	19.5	23.0
43.3	110	1.0	2.0	3.0	4.0	5.0	5.5	6.5	7.0	7.5	8.5	9.0	10.0	11.0	12.0	13.0	14.5	16.5	19.0	22.5
48.9	120	1.0	2.0	3.0	4.0	4.5	5.5	6.0	7.0	7.5	8.0	9.0	10.0	10.5	11.5	13.0	14.5	16.0	18.5	22.0
54.4	130	1.0	2.0	3.0	3.5	4.5	5.0	6.0	6.5	7.5	8.0	8.5	9.5	10.5	11.5	12.5	14.0	16.0	18.0	21.5
60.0	140	1.0	2.0	3.0	3.5	4.5	5.0	5.5	6.5	7.0	7.5	8.5	9.0	10.0	11.0	12.0	13.5	15.5	17.5	21.0
65.6	150	1.0	2.0	2.5	3.5	4.0	5.0	5.5	6.0	6.5	7.5	8.0	9.0	9.5	10.5	12.0	13.0	15.0	17.0	20.5

Values were calculated using Equation 3-3, Wood Handbook: Wood as an Engineering Material, 1999, FPL-GTR-113.⁴
See Chapter 3, Wood Handbook for further information. Values have been rounded to nearest 0.5%.

STRUCTURAL SIGNIFICANCE

Seasoning checks have limited effect on the strength of glued laminated timbers. In bending members, checks affect only the horizontal shear strength and are not of structural importance unless the checks are deep or occur near mid-depth of the member near its support. In compression members, checks are not of structural importance unless they develop into a split that increases the slenderness ratio of the member. If a preliminary inspection indicates that checks appear to fit either of these situations, a detailed evaluation should be performed by a qualified design professional.

FIELD INSPECTION

Using a feeler gauge or other similar probe, the depth of all checks thought to be significant should be measured. A sketch should be prepared locating each check indicating its length, depth, and width. The ends of the checks should be carefully marked on the members and the date of observation should be recorded to allow monitoring of subsequent changes.

The moisture content of the member at the time of inspection should be measured and recorded to determine the magnitude of drying which has occurred relative to the original moisture content at the time of manufacturing and to the expected equilibrium moisture content of the structure. These measurements should be taken at the surface and at some depth of the member using a resistance type moisture meter to determine the moisture gradient.

An assessment of nearby elements and surrounding conditions should be made to identify possible causes for increased checking. The location of heat ducts or heaters should be noted. Exposure to environmental conditions leading to direct wetting and drying by the elements or other environmental conditions which might lead to moisture cycling in the member should also be noted.

EVALUATION OF STRUCTURAL CAPACITY

If the field inspection indicates that checks do not penetrate more than 15% across the width of the member, no further analysis is necessary. If checks exceed this limit, a detailed evaluation should be performed by a qualified design professional. Guidelines are given below for both compression members (columns) and bending members (beams).

Compression Members

Checks do not affect the strength of compression members unless they become splits. A split is a lengthwise separation of the wood extending from one surface of the piece through to another surface. Small splits sometimes occur at the ends of the pieces, especially when drying is rapid. The occurrence of long splits in laminated timbers is rare. When a split occurs, it typically will only develop over a partial length of the member.

If an inspection verifies that a check has become a split, the structural integrity of the member should be re-evaluated based on the new slenderness ratio (l/d) resulting from the split. For

example, if a split approximately 7 ft long develops across the narrow width of a 6-3/4 in. x 9 in. column such that the least dimension of the member along the split is 3 inches (Figure 1). For the original section, with an effective length of 12 ft, the ℓ/d ratio is 21.3 (i.e. 144 in./6.75 in.). However, after the split has occurred, the ℓ/d ratio for the split length is 28.0 (i.e. 84 in./3 in.). Therefore, the load carrying capacity of this member has been reduced. The resultant load carrying capacity, taking the split into account, should be determined and compared to the actual load carrying requirements of the member to determine if reinforcement or other remedial repairs are needed.

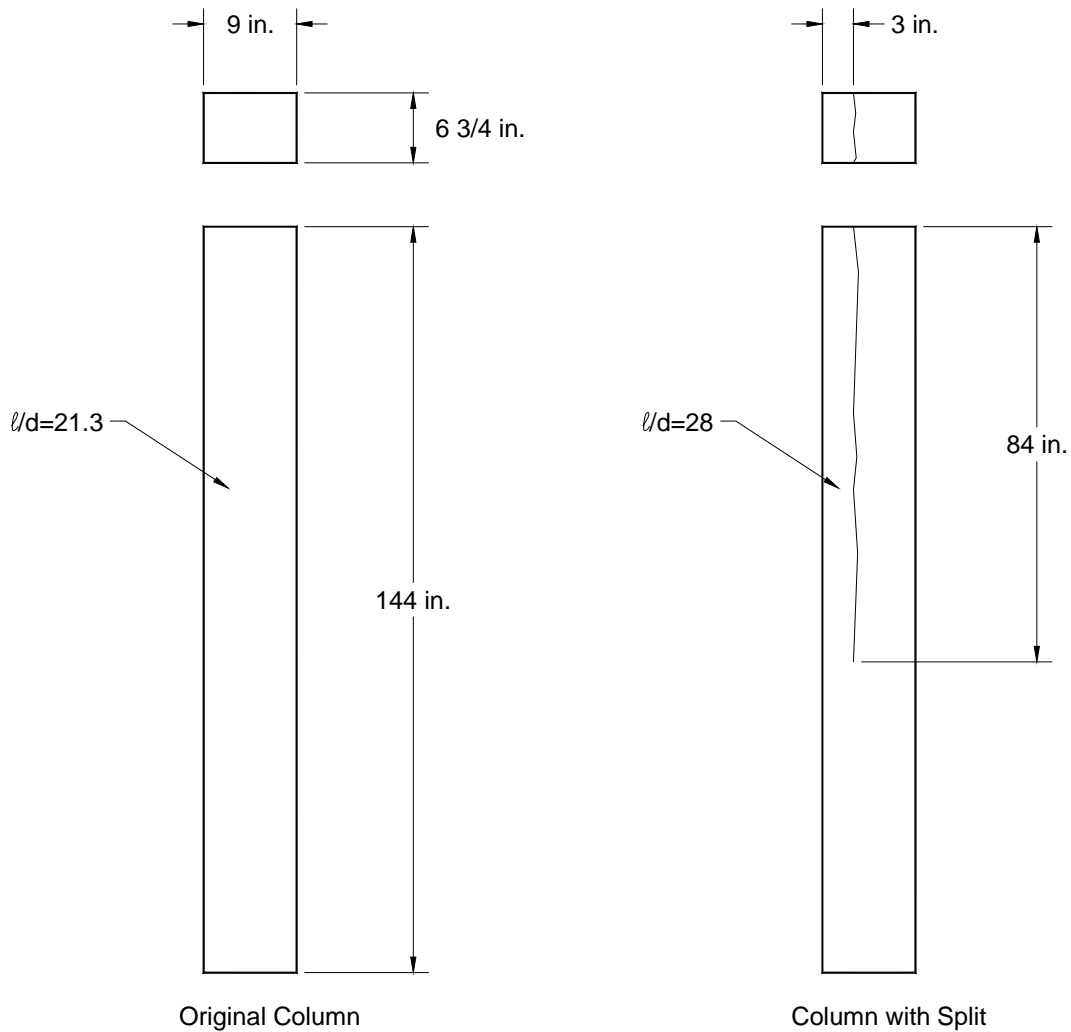

Figure 1. *Effect of split on column slenderness ratio.*

Bending Members

Checking can affect the shear capacity of bending members by reducing the effective shear resistance area. However, a minor amount of checking will not reduce the beam capacity. Based

on experience, judgment, and research (2,3), no reduction in shear capacity is recommended for beams with checks up to 15% of the beam width. These values have been calculated and are included in **Table 2** for common beam widths.

Table 2. *Allowed check sizes with no capacity reduction without further analysis.*

Beam Width (in.)	Allowable Check Size (in.)
2-1/2	3/8
3, 3-1/8, 3-1/2	1/2
5, 5-1/8, 5-1/2	3/4
6-3/4	1
8-1/2, 8-3/4	1-1/4
10-1/2, 10-3/4	1-1/2

Therefore, in most cases, the effect of checks in glued laminated timber can be ignored. When checks exceed 15% of the beam width, the steps to determine the impact of checking on a glued laminated beam are:

1. Determine the effective size of the check.
2. Determine the allowable check size for no capacity reduction.
3. Compare the effective size of the check to the allowed size for no capacity reduction at the check location.
4. If effective check size is greater than the allowed size, calculate a shear stress reduction factor.
5. Determine the adequacy of the beam under design loads.

Effective Size of Check

Side checks and end checks are illustrated in **Figure 2**. The effective size of a side check is its average depth (d_1) near the section of interest. The effective size of an end check is one-third of its average length and can be calculated with Equation 1 (see Figure 2).

$$l_0 = \frac{1}{3} \left(\frac{l_{01} + l_{02}}{2} \right) \quad [1]$$

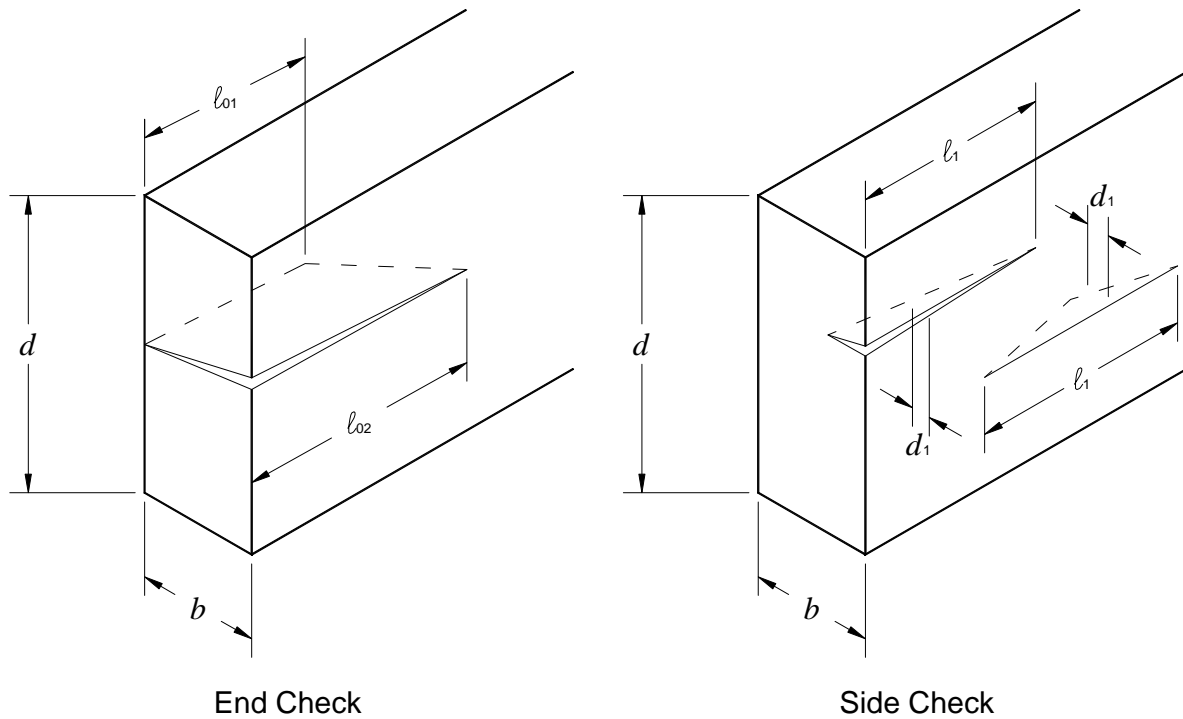

Figure 2. Determination of effective check size.

Allowable Check Size without Capacity Reduction

Checks with an effective size (l_0 or d_1) of up to 15% of the width ($0.15b$) are allowed anywhere in the cross-section without further analysis of capacity reduction. Larger checks, up to a maximum of 80% of the width ($0.8b$) are permitted without capacity reduction if they occur away from the mid-depth of the member. Maximum allowable check sizes (as a fraction of beam width) without a capacity reduction are defined by Equation 2 and illustrated in Figure 3. The length (l_1) is not restricted.

$$0.15 \leq F_w = 4 \left(\frac{y}{d} \right)^2 \leq 0.80 \tag{2}$$

- where: F_w = maximum allowed fraction check size without capacity reduction
- y = vertical distance from neutral axis to check
- d = beam depth

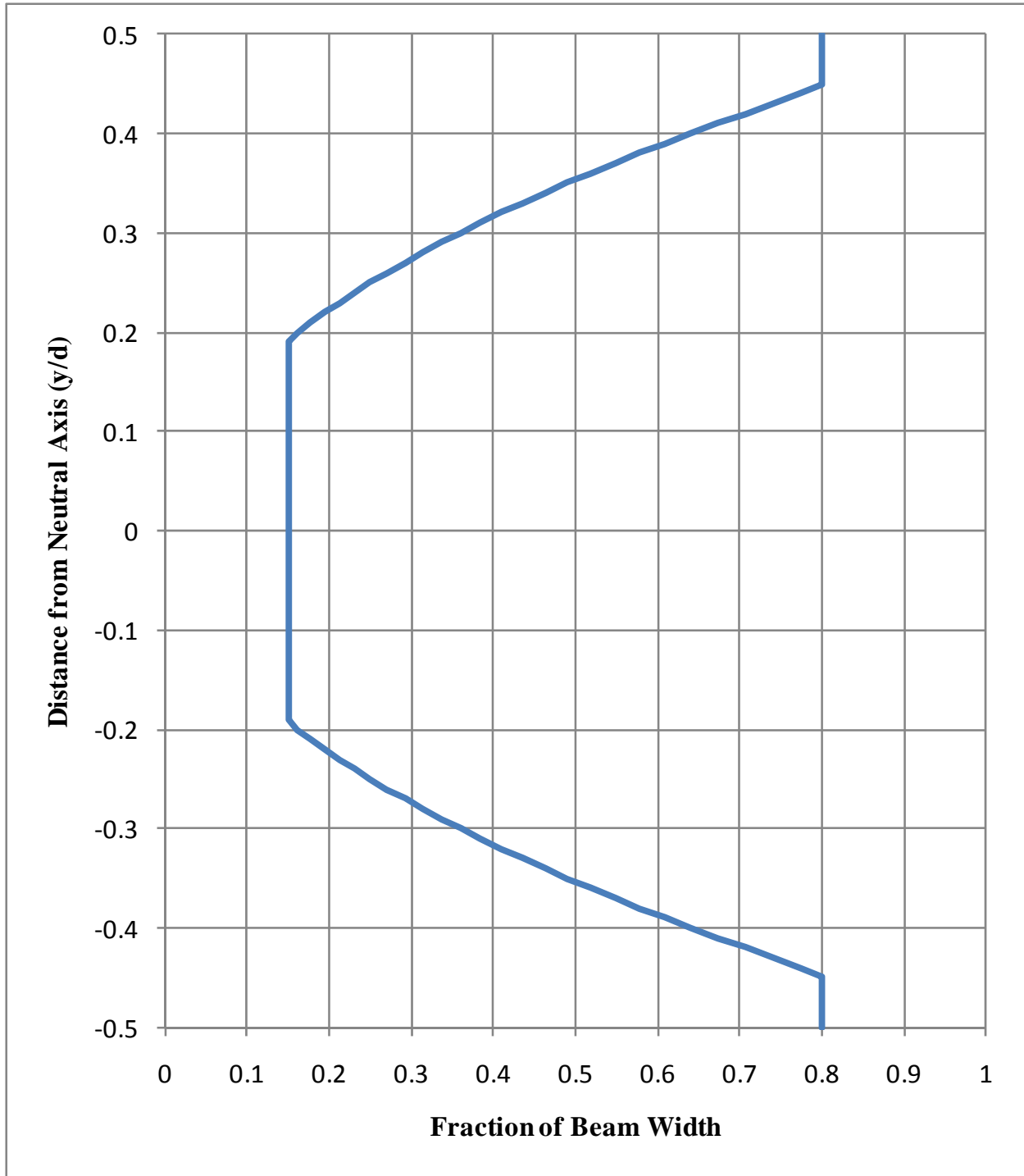

Figure 3. Maximum check size (F_w) in a glulam beam with no capacity reduction.

Shear Capacity Reduction Factor (C_{vc})

If the size of the observed check (s/b) exceeds the allowable check size (F_w) as calculated above, the shear capacity of the member must be evaluated. The shear capacity reduction factor for checking (C_{vc}) is calculated using Equation 3.

$$C_{vc} = \frac{\left(1 - \frac{s}{b}\right)}{(1 - F_w)} \leq 1.0 \quad [3]$$

where: C_{vc} = shear capacity reduction factor for checking

s = effective check size = ℓ_0 or d_1

b = beam width

F_w = maximum allowed fractional check size without capacity reduction

Beam Evaluation

For a given loading, the shear force at any cross-section along the length of a beam can be determined using solid mechanics. The shear force in the cross section at the location of the check(s) being evaluated should be compared to the reduced design shear capacity, with the following requirement:

$$\frac{2bdF'_v}{3} C_{vc} \geq V \quad [4]$$

where: F'_v = reference shear design value multiplied by all applicable adjustment factors except C_{vc}

C_{vc} = shear capacity reduction factor for checks

V = shear force on cross section due to applied loads

Example: Evaluate Checked Beam

Given:

- Beam Dimensions:

$$b = 5.125 \text{ in}$$

$$d = 24 \text{ in}$$

$$L = 28 \text{ ft}$$

- Load:

$$\omega = 850 \frac{\text{lb}}{\text{ft}}$$

- Side checks illustrated in Figure 4.

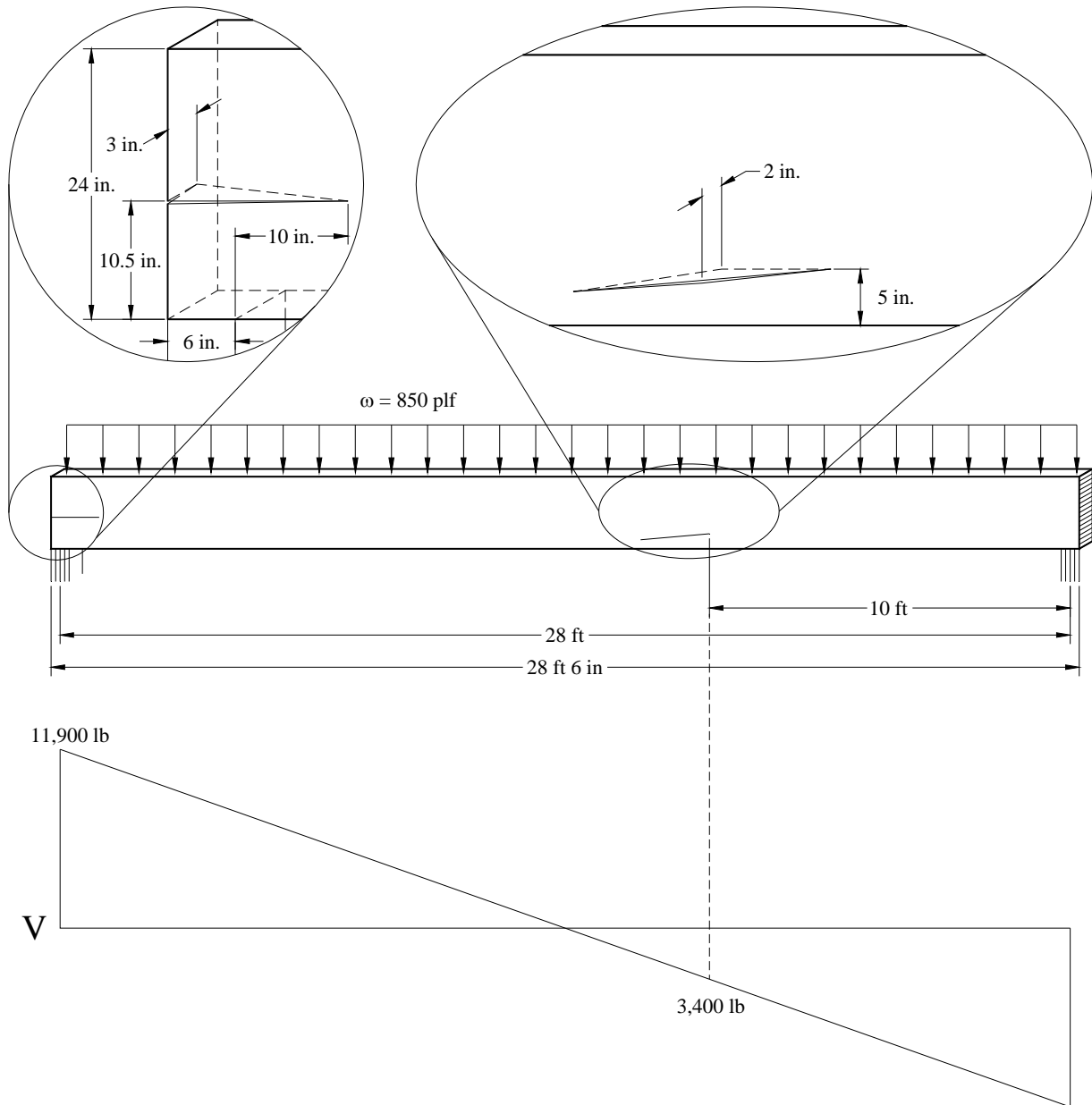

Figure 4. Example beam with load and shear diagrams.

Wanted:

- Determine effective check sizes.
- Determine location of checks relative to neutral axis.
- Determine allowable check sizes for no capacity reduction.

- Calculate shear capacity reduction factors.
- Compare shear capacity to shear load on each section.

Solution:**Effective check sizes:**

The effective check size for the check at the left end of the beam will be approximated as the check depth at the center of the support.

$$d_{1, \text{leftend}} = \left(\frac{3 \text{ in}}{16 \text{ in}} \right) (13 \text{ in}) = 2.44 \text{ in}$$

The effective check size for the check near the middle of the beam will be assumed to be the maximum measured check depth.

$$d_{1, \text{middle}} = 2 \text{ in}$$

Location of checks relative to neutral axis:

$$y_{\text{leftend}} = \frac{24 \text{ in}}{2} - 10.5 \text{ in} = 1.5 \text{ in}$$

$$\frac{y_{\text{leftend}}}{D} = \frac{1.5 \text{ in}}{24 \text{ in}} = 0.06$$

$$y_{\text{middle}} = \frac{24 \text{ in}}{2} - 5 \text{ in} = 7 \text{ in}$$

$$\frac{y_{\text{middle}}}{D} = \frac{7 \text{ in}}{24 \text{ in}} = 0.29$$

Maximum check sizes for no capacity reduction:

$$F_w = 4 \left(\frac{y}{d} \right)^2 \geq 0.15$$

$$F_{w,0.06} = 4(0.06)^2 = 0.014 \geq 0.15$$

$$F_{w,0.06} = 0.15$$

$$F_{w,0.29} = 4(0.29)^2 = 0.34 \geq 0.15$$

$$F_{w,0.29} = 0.34$$

Effective check sizes vs. maximum sizes without capacity reduction:

$$d_{1, \text{leftend}} = 2.44 \text{ in} > F_w b = 0.15(5.125 \text{ in}) = 0.77 \text{ in} \quad \therefore \text{Capacity reduction is required}$$

$$d_{1, \text{middle}} = 2.0 \text{ in} > F_w b = 0.34(5.125 \text{ in}) = 1.74 \text{ in} \quad \therefore \text{Capacity reduction is required}$$

Shear capacity reduction factors:

$$C_{vc} = \frac{\left(1 - \frac{s}{b}\right)}{(1 - F_w)} \leq 1.0$$

$$C_{vc, \text{leftend}} = \frac{\left(1 - \frac{d_{1, \text{leftend}}}{b}\right)}{(1 - F_w)} = \frac{\left(1 - \frac{2.44 \text{ in}}{5.125 \text{ in}}\right)}{(1 - 0.15)} \leq 1.0$$

$$C_{vc, \text{leftend}} = 0.62$$

$$C_{vc, \text{middle}} = \frac{\left(1 - \frac{d_{1, \text{leftend}}}{b}\right)}{(1 - F_w)} = \frac{\left(1 - \frac{2.0 \text{ in}}{5.125 \text{ in}}\right)}{(1 - 0.34)} \leq 1.0$$

$$C_{vc, \text{middle}} = 0.92$$

Reduced design shear capacities vs. shear forces on each section:

$$V'_{\text{leftend}} = \frac{2bdF'_v}{3} C_{vc, \text{leftend}} = \frac{2(5.125 \text{ in})(24 \text{ in})(265 \text{ psi})}{3} (0.62) = 13,500 \text{ lb}$$

$$V_{\text{leftend}} = 11,900 \text{ lb} \leq V'_{\text{leftend}} = 13,500 \text{ lb} \quad \therefore \text{OK}$$

$$V'_{\text{middle}} = \frac{2bdF'_v}{3} C_{vc, \text{middle}} = \frac{2(5.125 \text{ in})(24 \text{ in})(265 \text{ psi})}{3} (0.92) = 19,900 \text{ lb}$$

$$V_{\text{middle}} = 3,400 \text{ lb} \leq V'_{\text{middle}} = 19,900 \text{ lb} \quad \therefore \text{OK}$$

Discussion:

Both checks in this example resulted in a reduced shear capacity at their respective sections, however, the original unchecked beam had excess shear capacity at both sections. Analysis of the beam at the sections with the checks demonstrated that the beam is still sufficient to support the design loads.

In this example, the shear loads were chosen at locations of their greatest magnitude along the length of the check being considered. Check sizes were also estimated somewhat conservatively. The analysis could be refined with more precise information, but such refinement is generally unnecessary.

REFERENCES

1. AITC. 1987. *Checking in Glued Laminated Timber, Technical Note 11*. American Institute of Timber Construction, Centennial, CO.
2. Peterson, J. N. 1995. *Shear Strength of Checked and Split Southern Pine Lumber*. Master's Thesis. Washington State University. Pullman, Washington.
3. Murphy, J.F. 1980. *Strength of Wood Beams with Side Cracks*. Prepared for International Union of Forestry Research Organizations Timber Engineering Group s5.02. Oxford, England. Available from USDA Forest Products Laboratory, Madison, Wisconsin.
4. USDA. 1999. *Wood Handbook: Wood as an Engineering Material*. FPL-GTR-113. U.S. Department of Agriculture. Forest Products Laboratory. Madison, Wisconsin.