

# American Institute of Timber Construction

## Test Methods for Structural Glued Laminated Timber



Adopted as Recommendations, April 23, 2007

Copyright 2007

By

**AMERICAN INSTITUTE OF TIMBER CONSTRUCTION**

7012 S. Revere Parkway, Suite 140

Centennial, Colorado 80112

# AITC Test Methods

Adopted as Recommendations, April 23, 2007  
Copyright 2007 by American Institute of Timber Construction

## CONTENTS

AITC Test T102 – Adhesive Spread Measurement.....	1
AITC Test T103 – Calibration of Plant Pressure System: Bolts or Screw Type Jacks.....	4
AITC Test T104 – Calibration of Torque Wrenches.....	8
AITC Test T105 – Diagnostic Test for Finger Joint Quality.....	11
AITC Test T107 – Shear Test.....	15
AITC Test T110 – Cyclic Delamination Test.....	19
AITC Test T115 – Machining Test for End Joints.....	22
AITC Test T116 – Modulus of Elasticity for E-Rated Lumber by Static Loading.....	24
AITC Test T118 – Bending Proof Loading for End Joints.....	26
AITC Test T119 – Full Size End Joint Tension Test.....	30
AITC Test T121 – Tension Proof Loading for End Joints.....	32
AITC Test T122 – Mix Ratio Check for Automatic Adhesive Mixing Machines.....	35
AITC Test T123 – Sampling, Testing and Data Analysis to Determine Tensile Properties of Lumber.....	37
AITC Test T124 – Reinspection or Testing of Individual Lots of E-Rated Lumber for Conformance to Specs.....	41



# American Institute of Timber Construction

7012 South Revere Parkway • Suite 140 • Centennial, CO 80112  
Phone: 303/792-9559 Fax: 303/792-0669

---

## AITC TEST T102-2007 ADHESIVE SPREAD MEASUREMENT

Adopted as Recommendations, April 23, 2007  
Copyright 2007 by  
American Institute of Timber Construction

### **T102.1. SCOPE.**

This method describes procedures for the determination of the adhesive spread rate on lamination face surfaces when the adhesive is applied by either extruder or roller spreader.

### **T102.2. APPARATUS.**

Scale, having a sensitivity of one tenth (0.1) of a gram.

Adhesive applicator: roller, extruder. Applicator shall be the same applicator that is used for normal production.

### **T102.3. PRECAUTIONS.**

When short pieces of lumber are used and drive rollers are used to propel the lamination test piece through the adhesive applicator, the drive speed shall be adjusted to compensate for the shorter length as compared to the full length laminations normally used. Any change to the drive speed shall be accompanied by associated changes to extruder flow rate (if used) and calibrated to correlate to the drive speed/spread rate used in actual production.

### **T102.4. SAMPLING.**

#### **T102.4.1. Sample Size.**

Each test consists of one specimen; however, multiple specimens shall be required when the adhesive spread rate is adjusted by trial runs.

#### **T102.4.2. Frequency.**

Sampling shall be at the beginning of each shift and when production variables change, such as line speed, adhesive flow rate, lamination size, or temperature.

### **T102.5. TEST SPECIMEN.**

Any pre-weighed tape, paper strip, wood strip or other material that is light enough to allow for measurement of the adhesive weight on its surface shall serve as a specimen.

- Tape or paper strip, 2 in. wide by 15 7/8 in. long or 3 in. wide by 10 9/16 in. long. These sizes have been calibrated for ease of use. Other sizes may be used provided a calibration is developed. A wood strip or piece of lumber may also be used.
- Lumber piece, 6 to 8 ft. long, unless tape is not used.
- Liquid adhesive, pre-mixed prior to application.

## **T102.6. CALIBRATION.**

### **T102.6.1. Scales.**

The scale(s) to be used for this test shall be checked for accuracy through the use of known weights, or other suitable means. Verification shall be frequent enough to ensure proper measurement, but not less than once per calendar year.

### **T102.6.2. Extruders.**

Where extruder type applicators are used, the perforated tubes with different sized holes shall be identified and designated for use as required by the Quality Control Supervisor.

### **T102.6.3. Gauges.**

Any gauge settings that can be preset to adjust the adhesive flow rate, or line speed to achieve a given spread rate shall be verified by this test.

## **T102.7. PROCEDURE.**

### **T102.7.1. Summary of Method.**

A paper strip or length of tape of a known surface area is weighed, attached to a lamination face, then passed through the adhesive applicator (a wood strip or piece of lumber may also be used). The final weight of the paper or tape covered with adhesive is then determined and used to compute the weight of adhesive applied per unit area.

### **T102.7.2. Roller Spreader Application.**

When the adhesive is applied by rollers, the spread rate shall be determined in the following manner.

- (a) The weight of a short test piece of lumber of the same width and thickness as the laminations shall be determined. This test piece shall be run through the adhesive applicator, which will spread adhesive on one or both faces, then reweighed. The increase in weight represents the weight of the adhesive. The increase in weight shall be divided by the total surface area of the test piece to determine the spread rate.
- (b) An alternate method is to attach a paper strip on a lamination before it is run through the adhesive applicator and then peel it off afterwards. When adhesive is spread on both faces by rollers, rate of spread for both top and bottom rollers must be determined. The weighing and calculating operations are the same as for the wood block when the adhesive is spread by an extruder.

When the adhesive is spread by rollers, a coefficient which compensates for type and thickness of paper must be used. The coefficient shall be calculated as follows:

1. A wood strip 3 in. wide by 48 in. long of a uniform thickness and a piece of paper tape 3 in. wide by 24 in. long shall be weighed. The weight of each shall be recorded.
2. The combined wood strip and paper tape shall be passed through the adhesive applicator. Any extraneous adhesive that may have been applied to the edges or ends shall be completely removed by wiping. The tape shall be carefully removed and weighed, and the weight of the wood strip shall be determined. The quantity of adhesive that has been applied to the tape and the quantity of adhesive that has been applied to the wood shall be determined and recorded. The ratio that exists between the weight of adhesive applied to the tape and the weight of adhesive applied to the wood is the multiplying factor. Several tests shall be run to establish an accurate conversion factor.

### T102.7.3. Extruder Application.

When adhesive is applied by extruder, the spread rate shall be determined in the following manner:

- (a) A paper strip attached to a lamination shall be passed through the extruder. The strip shall be attached to the lamination diagonally rather than parallel to the sides of the laminations (Figure T102.1). The strip shall be located closer to (but not at) the tail end of the lamination rather than the leading end, to assure that the full speed of travel is attained by the time the paper strip passes through the extruder.
- (b) The spread rate shall be determined by weighing the tape after passing through the extruder, and comparing the weight of the adhesive to the area of the paper strip.
- (c) For ease and simplicity, the size of the paper strip can be such that the applied adhesive weight in grams can be multiplied by 10 and the resulting product is the spread rate in pounds per 1,000 sq. ft. of adhesive. For 2 in. wide paper, the length shall be 15-7/8 in.; and for 3 in. wide paper, the length shall be 10-9/16 in.

### T102.8. INTERPRETATION OF RESULTS.

Spread rate adequacy shall be judged on the basis of the adhesive manufacturer's recommendations for the assembly time and bonding conditions in combination with the basic adhesive qualification data recorded when the adhesive was originally qualified for use in the plant.

### T102.9. REPORT.

Spread rate measurements (to the nearest pound per 1,000 sq. ft.) shall be included with daily records. Measurements shall be recorded and reported for the beginning of each shift and each change in production variables.

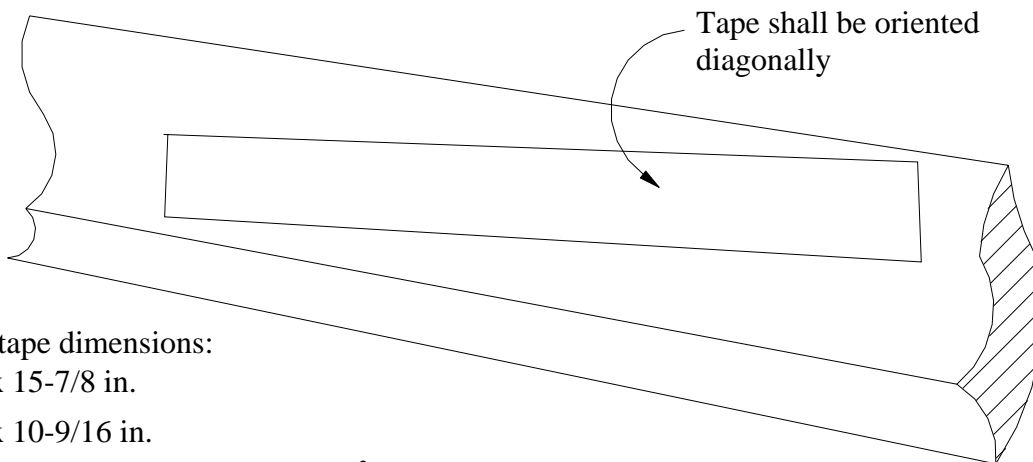

Calibrated tape dimensions:

- 2 in. x 15-7/8 in.
- 3 in. x 10-9/16 in.

Adhesive spread in pounds per 1,000 ft<sup>2</sup> of adhesive

Spread Rate (lb/ft<sup>2</sup>) = net weight of adhesive (g) x 10

Figure T102.1

### Tape Orientation for Extruder Application



# American Institute of Timber Construction

7012 South Revere Parkway • Suite 140 • Centennial, CO 80112

Phone: 303/792-9559 Fax: 303/792-0669

---

## AITC TEST T103-2007 CALIBRATION OF CLAMPING SYSTEM: BOLTS OR SCREW TYPE JACKS

Adopted as Recommendations, April 23, 2007

Copyright 2007 by

American Institute of Timber Construction

### T103.1. SCOPE.

This document describes methods for calibrating the bolts or screw-type jacks used to apply pressure to laminations in a plant's clamping system. Procedures are included for measuring and correlating force and torque on bolts or jacks and the establishment of torque requirement for specific spacings of bolts or jacks, arrangements of bolts or jacks, and various widths of lumber being laminated.

### T103.2. APPARATUS.

- (a) Compressometer, hydroplat, load cell, or other suitable device for measuring compressive force. These devices may have a solid piston or a piston with a hole in it for use with a single bolt. The compressometer gauge may be marked in units of force exerted by the ram or piston, or in unit pressure (psi) exerted on the piston or ram. The compression measuring device must be calibrated professionally, traceable to NIST.
- (b) Torque Wrench: Any type of torque wrench is permitted to be used provided that it can be calibrated, and that the calibration is maintained as described in AITC Test T104, or calibrated at least monthly by an accredited calibration laboratory. The same method of reading the torque wrench that is used in production shall be used in the calibration of bolts or jacks.
- (c) Racks or stands for conducting testing: Usually the calibration can be done in the same forms used for production.
- (d) Bolts or jacks: A random sampling of bolts or jacks taken from a collection of those used in production.
- (e) Miscellaneous short blocks or spacers.

### T103.3. PROCEDURE.

#### T103.3.1. Summary of Method.

Bolts or screw-jacks are randomly selected from those used in the production clamping system for face-bonding. Each bolt or jack is tightened with a torque wrench to specified levels of torque, and the corresponding clamping force is measured with a compressometer, hydroplat, load cell, or other suitable type device. Alternatively, each bolt or jack is permitted to be tightened to apply specified levels of force on the force measuring device with the corresponding torque measured by a torque wrench.

The relationship between the specified torque and the average force is determined and used to create production charts relating bolt torque to bond line pressure for each plant setup.

### **T103.3.2. Selection and Preparation of Bolts or Jacks.**

10 bolts or jacks shall be selected randomly from those used in production. If significant damage is noted on any of the selected bolts or jacks, they shall be removed from production for replacement or repair, and others shall then be selected for the calibration. The bolts or jacks shall be lubricated in accordance with plant procedures.

### **T103.3.3. Test Setup.**

The bolt(s) or jack shall be placed in the stand or production forms so that the tightening procedure results in the same clamping force(s) that would occur under production conditions. The bolt(s) or jack and compression measuring device shall be assembled with blocking as shown in Figure T103.1. For bolted assemblies, enough filler blocking shall be used so that the assembly uses the full length of the bolt(s).

### **T103.3.4. Tightening of Bolts or Jacks.**

The bolt(s) or jacks shall be tightened using a torque wrench until the specified torque (or force) is reached. The method of tightening shall duplicate plant conditions (i.e., if the torque is applied to the bolt head in production, the torque shall be applied to the bolt head in calibrating). When the two-bolt setup is used, the bolts (or nuts) shall be turned evenly, using a hand wrench, until the desired torque is reached on each bolt (or the specified force is reached).

### **T103.3.5. Measurement of Force and Torque.**

- (a) A minimum of five force versus torque readings shall be obtained per bolt or jack. These readings shall be taken at intervals of force spaced approximately evenly up to the full force to be developed by the bolt or jack.
- (b) Force shall be measured and recorded at each torque level for all 10 bolts or jacks. (For alternative method, torque shall be measured and recorded at each force level.)
- (c) When pairs of bolts are tested as shown in Figure T103.1, one-half of the force measured at the time each bolt reaches the specified torque shall be taken as the force reading for that bolt. (For the alternative method, the torque in each bolt shall be determined at the specified force.)

### **T103.3.6. Correlating Force and Torque.**

The average force reading for the ten bolts or jacks shall be calculated for each torque reading. The maximum and minimum force for each torque reading shall also be determined. (For the alternative method, the average, minimum, and maximum torque readings shall be determined for each force reading.) Simple regression shall be used to determine the average, minimum, and maximum forces as functions of the applied torque for a single bolt.

## **T103.4. CALIBRATION OF TORQUE WRENCH.**

The torque wrench used in the calibration of the bolts is itself calibrated at the same time. However, in order to check the day-to-day calibration of the wrench, the bolt used in the calibration that had torque versus force values closest to the average should be selected as the "average" bolt (see AITC Test T104). Torque wrenches are permitted to be calibrated by an accredited calibration lab if performed at least monthly.

### **T103.5. RELATING PRESSURE TO TORQUE.**

The pressure from a single bolt (or jack) is calculated by dividing the force for a single bolt (or jack) by the product of the spacing between bolts (or jacks) and the total width of laminations being clamped by that bolt (or jack).

### **T103.6. REPORT.**

Tables of torque vs. pressure shall be developed for each lamination width and bolt (or jack) spacing to be used in the plant. The torque tables shall be such that the bolt with the lowest force per increment of torque of the 10 bolts tested shall be capable of exerting a pressure of at least 100 psi on the face joint. The tables shall also be such that the bolt with the highest force per increment of torque of the 10 bolts tested shall not exert a pressure in excess of 250 psi at the maximum pressures used in the plant.

In practice, the average bolt (or jack) curve is often used with a value of 125 or 150 psi to set minimum torque levels for softwoods. When this is done, the pressure obtained from the lower value bolt at the same torque must be equal to or greater than 100 psi.

All charts and data sheets shall be dated. Quality control records shall document the forces and torques measured, and the name(s) of the person(s) performing the calibration.



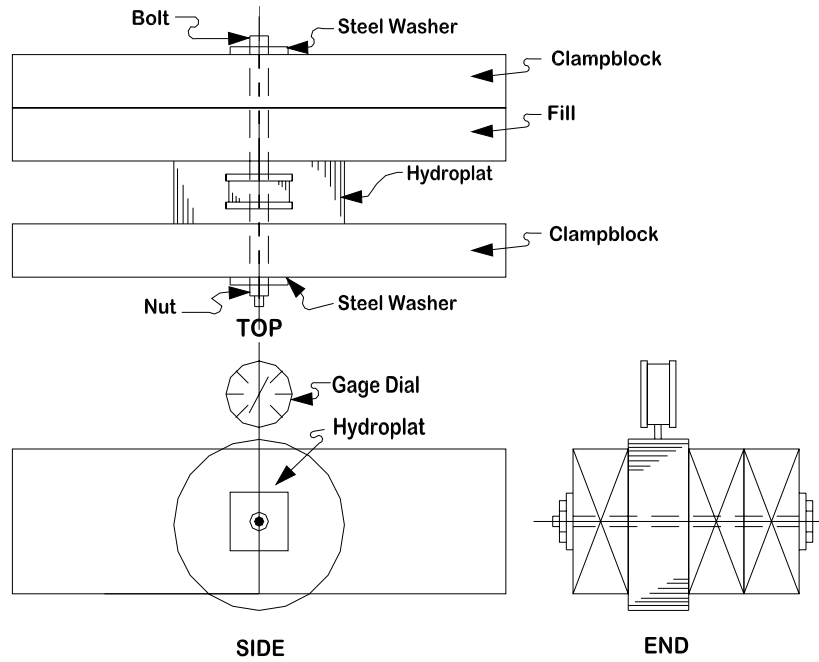

(A) Hydroplat with hole in center for calibrating single bolt

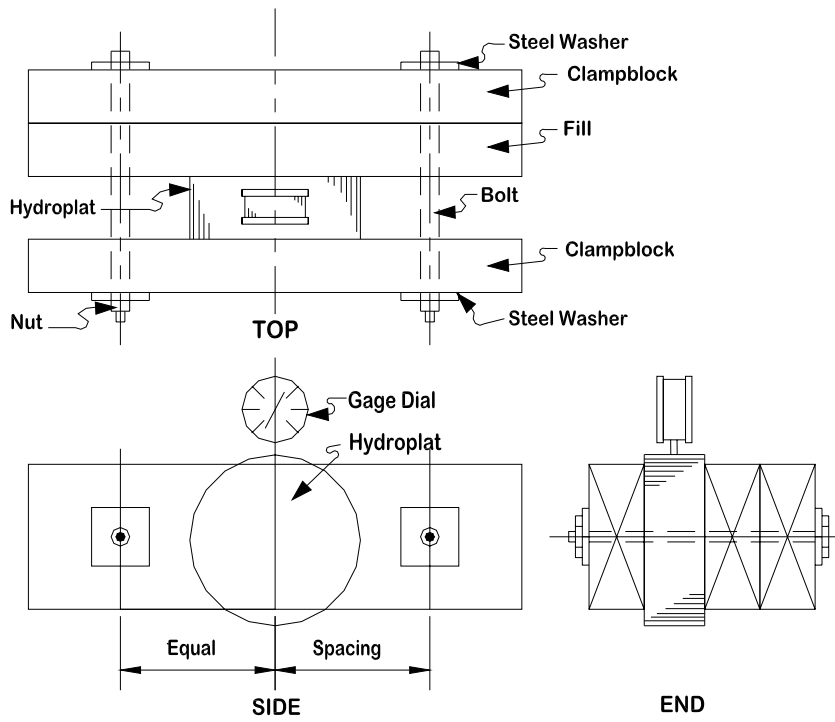

(B) Solid hydroplat for calibrating two bolts

Figure T103.1. Test setup for bolt or jack calibration.



# American Institute of Timber Construction

7012 South Revere Parkway • Suite 140 • Centennial, CO 80112  
Phone: 303/792-9559 Fax: 303/792-0669

## AITC TEST T104-2007 CALIBRATION OF TORQUE WRENCHES

Adopted as Recommendations, April 23, 2007  
Copyright 2007 by  
American Institute of Timber Construction

### T104.1. SCOPE.

This document describes methods for calibrating the torque wrench used to tighten the bolts or jacks used to apply pressure to laminations in a plant's clamping system. This test method describes the initial calibration of the torque wrench, and a system of maintaining the calibration.

### T104.2. APPARATUS.

- (a) Compressometer, hydroplat, load cell, or other suitable device for measuring compressive force. These devices may have a solid piston or a piston with a hole in it for use with a single bolt. The compressometer gauge may be marked in units of force exerted by the ram or piston, or in unit pressure (psi) exerted on the piston or ram. The compression measuring device must be calibrated professionally, traceable to NIST.
- (b) Torque Wrench: Any type of torque wrench is permitted to be used, provided that it can be calibrated. The same method of reading the torque wrench that is used in production shall be used in the calibration of the torque wrench.
- (c) Racks or stands for conducting testing
- (d) Bolt or jack: A bolt or jack representative of production is used to ensure consistent readings of the torque wrench at a known force.
- (e) Miscellaneous short blocks or spacers.

### T104.3. PROCEDURE.

- (a) The apparatus illustrated in Test T103 is used to verify the accuracy of torque wrench readings (or settings) by applying torque to the bolt(s) (or jack) at torque values ranging from the lowest to the highest values used in production.
- (b) The applied torque versus force relationship developed with AITC Test T103 shall be used to evaluate the torque wrench readings.
- (c) The test apparatus required in T104.2 shall be available for use on a daily basis. Torque wrenches shall be verified weekly at a minimum of three torque settings spanning the range of use.
- (d) When a pair of bolts is used as shown in Figure T104.1, each bolt shall be tightened to the same torque and the force used for calibration shall be taken as one-half of the force shown on the compression measuring device.

### T104.4. INTERPRETATION OF RESULTS.

Torque wrench settings shall not vary from the chart force values by more than 15% when compared to the values obtained in the original calibration. When results exceed this limitation, the torque wrench shall be taken out of use. Any corrective action taken shall be documented.

Bolt(s) or jacks used in the assembly must be well maintained and adequately lubricated to obtain reliable, reproducible results. High frictional forces may develop if bolts or washers are dry and/or damaged which can result in misleading force readings.

**T104.5. REPORT.**

A record of the torque wrench calibration readings shall be included in quality control records.

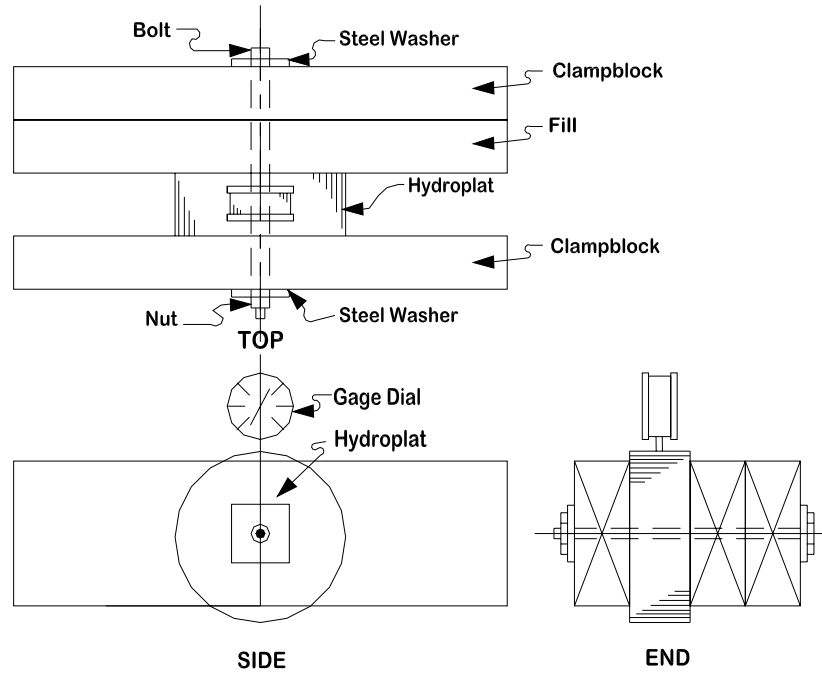

(A) Hydroplat with hole in center for calibrating single bolt

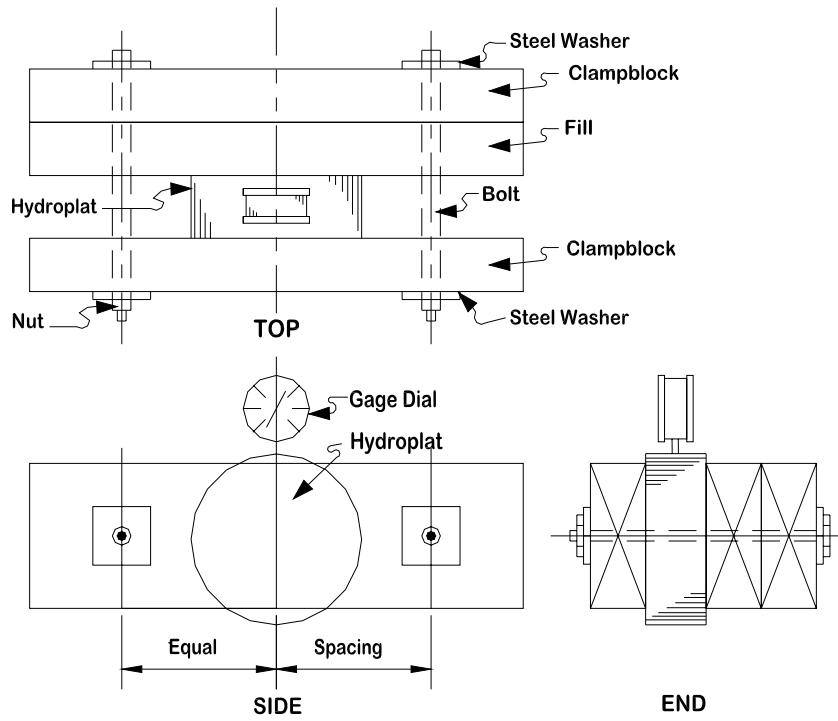

(B) Solid hydroplat for calibrating two bolts

Figure T104.1

**Equipment Setup for Calibration of Torque Wrench and Bolts**



# American Institute of Timber Construction

7012 South Revere Parkway • Suite 140 • Centennial, CO 80112  
Phone: 303/792-9559 Fax: 303/792-0669

---

## AITC TEST T105-2007

### DIAGNOSTIC TESTS FOR FINGER JOINT QUALITY

Adopted as Recommendations, April 23, 2007  
Copyright 2007 by  
American Institute of Timber Construction

#### **T105.1. SCOPE.**

This document describes tests intended for pre-production or interim evaluation of principal phases of the end joint manufacturing process. The tests shall be used to evaluate the adequacy of end joint profile (precision of cut), bond line cure, cured joint fit (alignment), bond line temperature and cured strength at the start-up phase of production or after any change in process variables.

#### **T105.2. DRY FIT, PRECISION OF PROFILE CUT.**

##### **T105.2.1. Summary of Method.**

A visual appraisal of the end joint fit is made on samples taken from production - prior to application of the adhesive. The end joint parts are fit together and visually inspected for fit along the cut surfaces for alignment (horizontally and vertically), for tip gap, and for squareness.

##### **T105.2.2. Apparatus.**

A clean, flat working surface, a hand square, calipers.

##### **T105.2.3. Sampling.**

One or more end joints are produced for evaluation prior to the start of production for the day, following a shift change, a change in the lamination width, or a change in cutting heads. In addition, end joint samples may be taken in an intermittent manner to verify production consistency of individual cutter heads. At a minimum, sampling shall follow:

- (a) Any major change in production variables, including the end joint curing sequence,
- (b) Replacement of end joint cutter heads.

##### **T105.2.4. Procedure.**

- (a) Samples shall be identified when they are selected relative to the cutting sequence and the top/bottom orientation.
- (b) The joint squareness shall be checked across the end and at the joint tips (for either horizontal or vertical configurations) using the square.
- (c) The consistency of the root depth throughout the joint shall be evaluated using the calipers.
- (d) The dry joints shall be assembled together and sufficient end pressure shall be applied to determine joint tip gap. For this step, the joint shall be placed on a flat clean surface to insure alignment of the narrow and wide faces. Very slight variations in tolerance may often be picked up more readily by reversing one side of the joint to amplify fit irregularities in the profile, which might not show up in the original orientation.

- (e) The joint shall be twisted by hand to attempt to induce movement along the cut surfaces due to inconsistent or inaccurate fit.

**T105.2.5. Interpretation of Results.**

Factors that can influence the accuracy of joint fit include:

- (a) Cutter head makeup.
  - 1. Tolerances on component parts.
  - 2. Conformance to recommended settings and maintenance procedures.
  - 3. The pattern of observed openings should be carefully noted. Concave or convex surfaces or irregularities along cut surfaces can be related to head maintenance.
  - 4. Short fingers can be the result of improper knife adjustment to the head setup fixture.
- (b) Cutter head motor and spindle alignment (motor bearings and lumber feed rates).
  - 1. Poor wood failure all on one side of the joint profile can be the result of vertical alignment of the head.
  - 2. Improper head balance can result in vibrations which can affect joint fit.
- (c) Lumber guides (alignment with cutter heads) and hold downs at the cutter heads.
  - 1. Movement of the lumber at the cutters can contribute to squareness and fit problems.
  - 2. Trim saw settings can affect squareness, finger length and tip thickness.

**T105.3. PARTIAL CURE - "HOT BREAK".**

**T105.3.1. Summary of Method.**

This test involves breaking an end joint in tension according to AITC Test T119 immediately after release from the RF adhesive curing process. This test is to be performed quickly, while the joint is still hot or warm.

**T105.3.2. Apparatus.**

A tension test machine as described in AITC Test T119 shall be used.

**T105.3.3. Sampling.**

One or more end joints are produced for evaluation prior to the start of production for the day, following a shift change, a change in the lamination width, or a change in cutting heads. In addition, end joint samples may be taken in an intermittent manner to verify production consistency of individual cutter heads. At a minimum, sampling shall follow:

- (a) Any major change in production variables, including the end joint curing sequence,
- (b) Replacement of end joint cutter heads.

**T105.3.4. Procedure.**

End joint shall be tested in tension to failure immediately after release from the heat cure process (within 2 to 5 minutes). Wood failure shall be evaluated primarily at this stage, with the strength approximation guidelines noted in section T105.3.5.

**T105.3.5. Interpretation of Results.**

Wood failure may be shallow and as low as 50% of optimum values when tested in the partially cured condition. Strength values will also be less than optimal; values beginning at approximately 70% of the average for a fully cured joint may be expected.

- (a) The depth and degree of wood failure shall be evaluated.
- (b) Poor bond line pressure can sometimes be diagnosed if the bond line has a glossy appearance, or is unusually thick. A spotty or chalky appearance may be an indication that the wood surfaces were not in uniform contact.

**T105.4. CURED JOINT FIT.**

**T105.4.1. Summary of Method.**

Fully cured end joints may be evaluated in laminations either in the pre-bond area (prior to face bonding), or in the finished member. This test involves removing cured adhesive squeeze out so that the joint profile can be inspected for bond line openings.

**T105.4.2. Apparatus.**

Hand planer or scraper suitable for removing the squeeze out from the exposed surfaces of cured end joints.

**T105.4.3. Sampling.**

End joints are evaluated visually in the finished laminations, or in the finished member. Focus of the sampling scheme should be compatible with the lot sampling objectives.

**T105.4.4. Procedure.**

End joint profiles to be evaluated shall be cleaned sufficiently to determine whether or not bond line openings, jammed fingers, or other defects that may affect end joint strength are present.

**T105.4.5. Interpretation of Results.**

Any measurable bond line openings may reduce end joint strength or durability. , Affected laminations shall be repaired or replaced, and the process shall be corrected.

**T105.5. TEMPERATURE CHECK.**

**T105.5.1. Summary of Method.**

End joint bond line temperatures are measured through the use of a thermometer or thermocouple inserted in a hole drilled into the end joint. The temperature should be measured mid-depth in the lamination, approximately 2 inches in from the narrow face.

**T105.5.2. Apparatus.**

Temperature measurement device with a probe approximately 1/8 inch in diameter and 3 to 8 inches long. A hand drill and drill bit compatible with the temperature probe.

**T105.5.3. Sampling.**

Temperature checks shall be made at random during the course of end joint production and at the start-up stage.

**T105.5.4. Procedure.**

A hole shall be drilled to the mid-depth of the lamination approximately two inches from the narrow face of the piece, immediately after release from the heat cure process, and the thermocouple or thermometer shall be inserted into the hole. The temperature shall be recorded. For thermometers that respond slowly, consecutively drilled holes in successive end joints can serve to pre-heat the thermometer probe to improve chances of recording the peak temperature at the desired point of measurement.

**T105.5.5. Interpretation of Results.**

Target temperatures for specific adhesives shall be as required by the initial qualification results and shall meet the manufacturer's recommended temperature levels for the bonding condition involved. Adhesive manufacturer recommendations may vary for specific formulations of given adhesive types.

**T105.6. REPORT.**

All test results problems, corrective actions, re-tests, explanations, etc. shall be recorded in the daily quality control records.





# American Institute of Timber Construction

7012 South Revere Parkway • Suite 140 • Centennial, CO 80112  
Phone: 303/792-9559 Fax: 303/792-0669

---

## AITC TEST T107-2007 SHEAR TEST

Adopted as Recommendations, April 23, 2007  
Copyright 2007 by  
American Institute of Timber Construction

### **T107.1. SCOPE.**

This test is used to evaluate face bond line quality by measuring shear strength and wood failure.

The test procedure shall be used to fulfill daily production test requirements for face (and edge) joint bonding.

This test may be used to satisfy the daily test requirements for the radius repair procedure.

### **T107.2. SUMMARY OF METHOD.**

Specimens are prepared from production and sheared parallel to the grain along the face bond lines. The strength of the bond line is then compared with the average strength for the species. Wood failure is also evaluated. Corrective action may be required if results are low.

### **T107.3. APPARATUS.**

- (a) Shear tool capable of applying opposing loads parallel to the bond line of test specimens. An example may be found in ASTM D905. The shear tool shall be capable of approximating a uniform head speed not to exceed 0.50 in. per minute.
- (b) A calibrated ram suitable for use with shear tool.

### **T107.4. PRECAUTIONS.**

Proper specimen preparation and test procedures shall be maintained for reliable results.

Specimens shall be accurately cut. Rough or torn grain and cuts not perpendicular to the bond lines can affect results.

The shear tool shall load the specimen without excessive pivotal movement about the bearing surfaces.

Loading shall be parallel to the grain.

### **T107.5. TEST SPECIMENS.**

The species to be tested shall be the species used in production. Separate specimens must be tested for each adhesive-species-treatment combination occurring in production.

Specimens may be tested without special seasoning requirements except that the moisture content must be determined.

Specimens are to be obtained from production. One of the following 3 basic specimen types shall be used as described below (see Figure T107.1).

#### **T107.5.1. Stepped Block Type.**

This is the standard specimen for this test in accordance with ASTM D 905, except as noted in the test requirements in this section.

- (a) In nominal 6 and 8 in. wide members, 2 stair-step groups of block shear test specimens shall be cut from the available sample for testing face joint bonding. These test specimens shall come from the 2 outer edges of the member. In nominal 10 in. or wider members, 3 stair-step groups of block shear test specimens shall be cut, one from the center and one from each edge of the member. Single bond line block shear specimens may be cut in lieu of stair-step group specimens.
- (b) For block shear samples, the standard block shear test specimens shall include a minimum of 10 bond lines, including at a minimum the top, bottom and center bond lines. When a production member contains 10 or more bond lines, at least 10 block shear specimens from different bond lines shall be prepared and tested.
- (c) For edge joint bond testing with block shear specimens, the size may be modified according to the thickness of the lamination.

#### **T107.5.2. Core Type.**

The shear test may be performed on a cylindrical 1 in. diameter core sample. The method of sampling, rate of loading and criteria for wood failure and shear strength shall be the same as the standard block shear test. Prior to using this test, a correlation of shear values shall be made between a minimum of 20 block shear specimens and an equal number of core specimens. Matching specimens shall be obtained by cutting the test specimens from the same piece of laminated timber. The core specimens shall be taken as close to the block shear samples as cutting conditions permit. The ratio of average shear value of the core shear test to the average shear value of the block shear test shall be determined. The correlation obtained from this procedure shall be used to adjust the test values of the core test specimens to an equivalent block shear test value, but in no case shall a correlation factor greater than 1.0 be used.

#### **T107.5.3. Straight Block.**

A straight block type specimen may be used when correlated with the standard stepped block by the procedure described above for core type specimens. The straight block shall be used with or without saw kerfs at the bond lines, as long as the specimen to be used is properly correlated with the stepped type block specimen.

#### **T107.6. PROCEDURE.**

Specimens are loaded to failure with both the shear strength and wood failure recorded for each bond line tested. Each bond line shall be numbered on the specimen prior to testing.

The shear strength and wood failure shall be noted for each test performed.

#### **T107.7. INTERPRETATION OF RESULTS.**

##### **T107.7.1. Wood Failure.**

Wood failure shall be reported as a percentage of the bond line having failure in the wood fibers. The following steps shall be used for estimating wood failure:

- (a) It is necessary to examine carefully the bonding surfaces. Frequently, one surface will be very different in appearance from the other surface. Both sides shall be used in determination of the percent of wood failure.
- (b) Mentally divide the area of one side into fractional parts of the whole: tenths, quarters, thirds, halves. The percentage of the adhesive failure can then be mentally calculated and subtracted from 100. The data recorded, will be the percentage of wood failure. There will often be several areas, sometimes many small areas of adhesive failure. The technician should mentally transfer these

isolated areas into one larger area than can be understood as representing perhaps 1/10 or 1/4 of the entire area.

**T107.7.2. Shear Strength.**

The shear strength shall be reported in pounds per square inch of the sheared surface.

Specimens that show strength values below the required average for the species combined with wood failure values of 75% or more may be excluded in calculating the average test values. However, no more than 2 specimens per sample may be excluded from any single test group. When a specimen is excluded additional samples shall be selected to fulfill the specimen requirements for the sample.

**T107.8. REPORT.**

Record all test results for both strength and wood failure with notes included when supplemental specimens are required.

Further documentation is required for corrective action taken if results are less than the required average for the species tested.

Note the moisture content of the test sample on the data sheet.

Correlate results with specific production periods or job numbers.

**A. Standard Block Specimen:**

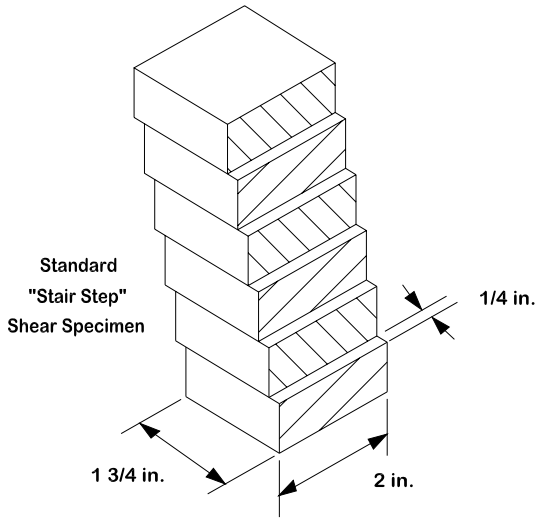

**B. Standard Core Specimen**

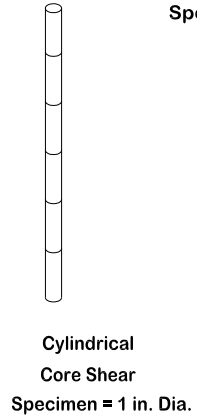

**C. Alternate Block Designs:**

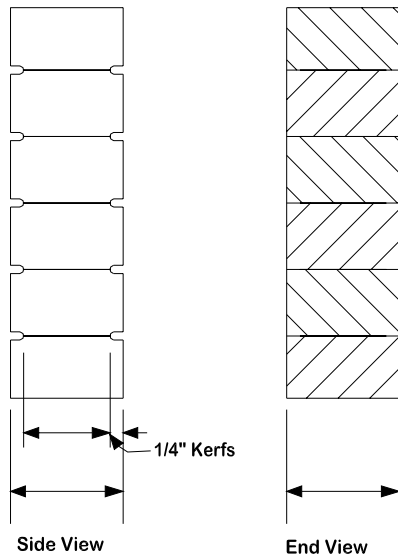

**Note:** The Shearing Tool is Modified to Hold the Specimen Glue Line Parallel to the Line of Force.

**D. Other Alternates to Block Shown in C Include:**

- (1) Alternating the Saw Kerf to Opposite Sides of the Glue Line -

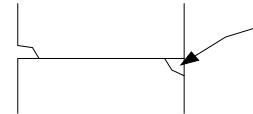

- (2) No Saw Kerfs at All; A Straight 1 1/2 in. x 2 in. Block



**Figure T107.1**

**Shear Specimen Alternatives**



# American Institute of Timber Construction

7012 South Revere Parkway • Suite 140 • Centennial, CO 80112  
Phone: 303/792-9559 Fax: 303/792-0669

## **AITC Test T110-2007 Cyclic Delamination Test**

Adopted as Recommendations, April 23, 2007  
Copyright 2007 by  
American Institute of Timber Construction

### **T110.1. SCOPE.**

This test describes a method for measuring the effects of accelerated cyclic exposure (vacuum-pressure-soak/rapid drying) on the bonds of samples from glued laminated timbers.

### **T110.2. APPARATUS.**

#### **T110.2.1. Autoclave.**

An autoclave or similar pressure vessel designed to safely withstand a minimum of 75 psi pressure shall be required for impregnating the specimens with water. The pressure vessel shall be equipped with a vacuum pump or similar device capable of drawing a vacuum of at least 25 in. of mercury (at sea level) in the vessel, and a pump or similar device for obtaining pressure of at least 75 psi (gauge pressure).

#### **T110.2.2. Drying Oven.**

A drying oven capable of maintaining a temperature of approximately 160 °F and conditions of relative humidity to dry the specimen to within 15% of its original weight within 10-15 hours shall be required.

Note: An oven with the capacity to maintain a relative humidity of 8% to 10% (70 °F wet bulb depression at dry bulb temperature of 160 °F) and to circulate the air at a rate of approximately 500 ft./minute past the end grain surfaces of the test specimens has shown to be sufficient to meet this requirement.

### **T110.3. PRECAUTIONS.**

The sample blocks must be dried rapidly (10-15 hours) if the optimum test on the bond line is to be achieved.

The delamination percentage must be determined immediately after removal from the oven. Otherwise, areas of poor bond may close up as the moisture gradient in the piece lessens due to the core drying and the surface picking up moisture.

### **T110.4. TEST SPECIMENS.**

#### **T110.4.1. Face bond evaluation.**

The test specimen shall be representative of production, but need not necessarily include all bond lines in a given member. However, each test specimen shall be a minimum of 6 in. in depth, or the full depth of the member section if less than 6 in. deep. The length of each specimen shall be 3 in.

#### **T110.4.2. End joint evaluation.**

The test specimen shall be prepared from a block with a minimum depth of 6 in. and a length of approximately 6 in. having end joints in one or more laminations in the section of interest at the center of the block, along the length. Individual end joints may be used when they are cut to expose the end joint in

section, or end joints may be included in the sawn surface(s) of the block samples used for face joint bonding.

- (a) The block shall be crosscut through the center of the joint(s) to create two test specimens, three inches long.
- (b) A sharp crosscut saw with a kerf of approximately 1/8 in. or less shall be used.
- (c) At least 0.25 in. of the length of the joint shall remain after cutting. If the length of the joint does not permit this to be met by cutting at the center of the joint, the joint shall be cut at the tips of the fingers or end of the scarf to yield one test specimen such that the full length of the joint is retained.

#### **T110.5. PROCEDURES.**

- (a) Test samples of face and end joint bonding shall be from production. The specimens are subjected to a vacuum-pressure-soak cycle in an autoclave followed by a drying period in an oven.
- (b) The bond lines are evaluated for delamination on the sawn (end) faces of the samples.
- (c) The weight of each test specimen shall be measured to the nearest gram and recorded.
- (d) The test specimens shall be placed in the autoclave or pressure vessel and weighted down. Stickers, wire screens, or other means shall be used to separate the test specimens so that all end grain surfaces are freely exposed to water.
- (e) Sufficient water shall be admitted at a temperature of 65 to 85°F, so that the test specimens are completely submerged.
- (f) A vacuum of 20 to 25 in. (510 to 640 mm) Hg shall be drawn and held for 30 minutes then released.
- (g) A pressure of 75±5 psi shall be applied for a period of two hours.
- (h) The test specimens shall be dried using air at a temperature of 160±5°F. The air circulation and number of specimens in the oven at any time shall be selected such that the specimens are dried to within 12-15% of their original weight in 10-15 hours.
- (i) During drying, the specimens shall be placed at least 2 inches (50 mm) apart, with the exposed bond lines on the end grain surfaces parallel to the direction of the airflow. . The actual time in the drying oven is controlled by the change in weight of the test specimens.
- (j) When the weight has returned to within 12-15% of the original test specimen weight prior to the beginning of the test, the specimens shall be removed from the oven, and the delamination is immediately measured and recorded.
- (k) The delamination is measured along the bond lines and is reported as a percentage of the sum total of bond line lengths on both sawn faces of the test sample block, or both sections of a single end joint that has been sawn in 2 parts prior to testing.

#### **T110.6. INTERPRETATION OF RESULTS.**

Areas of poor bond associated with knots or other grade characteristics that may have affected the results shall be recorded, but shall not be included in the computation for percentage of delamination.

Test blocks may be chiseled apart at the glue lines to further evaluate the bond line quality. Signs of poor bond line pressure and dry-out may be characterized by a glossy appearance of the adhesive surface.

For daily tests, if the delamination observed after one cycle exceeds 5%, the entire cycle shall be repeated. The delamination observed and recorded at the end of the second cycle shall not exceed 10%.

For adhesive qualification and lot tests, the delamination shall not exceed 5% for softwoods and 8% for hardwoods after a single cycle. A second cycle for qualification is not permitted.

**T110.7. REPORT.**

The weights before and after the conditioning shall be recorded.

The temperature of the oven, relative humidity, and time to final delamination reading shall be recorded.

The percentage of delamination shall be recorded for each specimen tested.

Corrective actions shall be documented in the daily records any time test results show delamination greater than 5%.



# American Institute of Timber Construction

7012 South Revere Parkway • Suite 140 • Centennial, CO 80112  
Phone: 303/792-9559 Fax: 303/792-0669

## **AITC Test T115-2007**

### **Machining Test for Scarf Joints**

Adopted as Recommendations, April 23, 2007

Copyright 2007 by

American Institute of Timber Construction

#### **T115.1. SCOPE.**

This test provides a method to evaluate the machining accuracy for scarf joints through the use of observations on the "dry fit" of production- run end joints.

#### **T115.2. SUMMARY OF METHOD.**

Production scarf joints are checked for precision of cut through the use of straight edge measurements at prescribed locations on the cut surfaces or assembled thickness measurements.

#### **T115.3. TEST SPECIMENS.**

Production-run scarf joints without adhesives - "dry" joints.

#### **T115.4. PROCEDURE.**

- (a) The joint surface shall be visually examined for accurate machining of a smooth surface.
- (b) The thickness of the tip of a plane scarf shall be measured to assure that it does not exceed 1/32 in.
- (c) A plane scarf joint shall be completely assembled with the positioning peg in place and then clamped together in the dry condition.
- (d) The assembled thickness is then measured at 3 places along the joint on both edges.
- (e) When the assembled thickness is within minus 0.005 in. to plus 0.020 in. of the lumber thickness, a good fit has been obtained and no further measurements are required.
- (f) When the assembled thickness is not within the required tolerances, the following procedures shall be used to determine the cause.
  1. The thickness along the cross section at any given point shall be measured by passing a plane perpendicular to the longitudinal axis of the piece. This plane shall be established by drawing a line perpendicular to the longitudinal axis at any point on the back or unscarfed side; then project up from the ends of this line on each side perpendicular to the back of the scarf. A fourth line connecting the ends of these projected lines shall be drawn across the face of the scarf. The thickness of one edge of the scarf, where the plane passes through, shall be measured and established as the base measurement. The thickness at the other side and other points along the cross section through which the plane passes shall also be measured.
  2. The plane of the scarf shall be checked by placing a straightedge along the face parallel to the longitudinal axis of the piece. The variation of the surface of the face from the straightedge shall be measured.



**T115.5. INTERPRETATION OF RESULTS.**

When the end joint assembled thickness measurements are verified to be within the specified tolerances, adequate face joint bonding in the area of the end joint is obtained. Where these assembled thickness measurements are not within the specified tolerances, adjustments are required to correct the variances. Corrective measures may include machine adjustments for tip thickness, register, and the plane of the cut.

**T115.6. REPORT.**

Assembled thickness measurements, appropriate comments on the fit and smoothness of the cut, and supplemental measurements made to verify the adequacy of any corrective actions shall be included in the test records. Corrective actions and any further testing shall be documented as well.



# American Institute of Timber Construction

7012 South Revere Parkway • Suite 140 • Centennial, CO 80112  
Phone: 303/792-9559 Fax: 303/792-0669

## AITC Test T116-2007

### Modulus of Elasticity of E-Rated Lumber by Static Loading

Adopted as Recommendations, April 23, 2007  
Copyright 2007 by  
American Institute of Timber Construction

#### **T116.1. SCOPE.**

This test describes procedures for determining the long-span modulus of elasticity (long-span E) for laminating lumber. The long-span E value of E-rated lumber is based on a static, flat-wise test with a center-point loading and a span-to-depth ratio (l/d) of approximately 100. The high span-to-depth ratio of the specimen minimizes the effects of shear deformation on the piece, making the long-span E a close approximation of the “true” flexural modulus of elasticity of a piece.

#### **T116.2. SUMMARY OF METHOD.**

A concentrated load of known weight is applied at mid-span of a simply supported piece of lumber oriented flat-wise. A dial indicator is used to determine the deflection of the lumber piece under the load. The long-span E is determined by relating the deflection to the size of lumber and the span.

#### **T116.3. APPARATUS.**

##### **T116.3.1. Supports.**

Any support system may be used that provides unrestrained support at both ends.

- (a) The support at one end should be constructed so that stability is provided for a piece of twisted lumber such as a pedestal with a single point bearing support, a support that is designed to tilt to match the twist of the lumber, or special shims that restrain the lumber from rocking on the supports.
- (b) The supports shall be sufficiently rigid to deflect less than 0.001 in. under the loads applied.

##### **T116.3.2. Deflection-measuring device.**

A dial indicator or equivalent with the capacity to measure deflections of 2 inches or more to the nearest 0.001 in. shall be required.

##### **T116.3.3. Weights.**

Two compact, accurately calibrated, known weights shall be used. - e.g. a 5 lb. weight, and a 10 lb. weight.

- (a) The weights shall be accurately calibrated to within 0.05 lb.
- (b) The weights shall be of such magnitude that small inaccuracies in reading deflection will have a negligible effect on the calculated long-span E value. (For a span of 12 feet, an average deflection of approximately 0.2 inches at E levels of  $1.5 \times 10^6$  to  $2.5 \times 10^6$  psi has worked well).
- (c) The weights shall be chosen to provide a precision of 61% or better at an E value of  $2.0 \times 10^6$  psi.
- (d) The loads used shall not create excessive deflection. (For very long spans the weights may need to be decreased).

#### **T116.4. PROCEDURE.**

- (a) The supports shall be spaced to provide a span-to-depth ratio of approximately 100 or more based on flat-wise bending of the piece of lumber.
- (b) The dial indicator (or equivalent deflection measuring device) shall be placed midway between the supports and adjusted so the downward deflection of the lumber can be measured when loaded.
- (c) The piece of lumber shall be placed flat-wise on the supports and checked to make sure that it is in firm contact with the end supports.
- (d) The first (smaller) weight shall be applied, and the dial indicator (or equivalent) shall be set to zero or the deflection reading shall be recorded.
- (e) The second (larger) weight shall be added and the deflection due to this weight shall be determined to the nearest 0.001 inch.

#### **T116.5. INTERPRETATION OF RESULTS.**

The long-span modulus of elasticity shall be calculated by the simple beam deflection equation:

$$E = \frac{P\ell^3}{4\Delta bd^3}$$

where:

$P$  = larger weight (lb.)

$\ell$  = span (in.)

$\Delta$  = measured deflection (in.)

$b$  = width of the piece

$d$  = thickness of the piece

When the length of a piece of lumber is too short to obtain a span-to-depth ratio of 100, the longest span possible shall be used. Available data indicates that the measured modulus of elasticity for a given type of loading will tend to be lower as the span-to-depth ratio decreases from approximately 70.

#### **T116.6. REPORT.**

Records shall include: specimen size, deflection measurements, weights used, the support spacing, and the calculated long-span E for each piece of lumber tested. The lumber grade and lot shall also be identified.



# American Institute of Timber Construction

7012 South Revere Parkway • Suite 140 • Centennial, CO 80112  
Phone: 303/792-9559 Fax: 303/792-0669

## AITC Test T118-2007

### Bending Proof Loading for End Joints

Adopted as Recommendations, April 23, 2007

Copyright 2007 by

American Institute of Timber Construction

#### **T118.1. SCOPE.**

The bending proof loading quality control test is intended to ensure the strength of end joints by testing at a stress level high enough to detect and reject low-strength end joints in tension laminations, but low enough to avoid causing damage in laminations passing the test. Proof loading may be performed on fully cured or partially cured end joints. The system provides a greater structural reliability by the rejection of low-strength end joints.

#### **T118.2. APPARATUS.**

##### **T118.2.1. Proof Loader.**

Any machine or device capable of providing a known bending load to the end joint shall be acceptable.

- (a) The loading device shall be capable of applying different loads for use with different lumber sizes and stress levels.
- (b) The proof-loader shall have all of the necessary controls, gauges, etc. to permit proof loading of all widths and thicknesses intended for production.

##### **T118.2.2. Failure Indicators.**

The proof loader shall be capable of detecting breaks or damage to low-strength end joints. The following devices are required.

A device capable of detecting excessive deflection which results in rejection of the end joint.

An audible warning device which sounds an alarm when a predetermined deflection limit is exceeded.

A device that applies a mark on one edge *and* one face at the end joint or point where the deflection limit has been exceeded.

##### **T118.2.3. Marking Device.**

A device that marks at least one edge at regular intervals along the proof loaded lamination shall be required if proof loading will be used to justify reduced end joint spacing intervals.

#### **T118.3. CALIBRATION.**

At a minimum, all measuring equipment shall be calibrated by the AITC Inspection Bureau prior to initial use and annually.

The force exerted by the proof loader shall be calibrated by the use of a proving ring or load cell. A calibration chart shall be prepared.

The actual fiber stress in bending of the lamination shall be calculated based on the loading and support restraints present. It shall be further checked by AITC using a piece of lumber of known stiffness in combination with strain measurements or other acceptable methods.

Calculations shall be made to determine the deflection limit of the lamination for the predetermined modulus of elasticity. The calculations shall be based on the loading and support conditions. These shall be verified by using of a piece of lumber with a known modulus of elasticity or other acceptable means.

#### **T118.4. PROOF LOAD LEVEL.**

The required bending stress induced by the proof load shall be determined from the following equation:

$$F_{pl} = 2.5R_1(QSL) \geq 1.5(QSL)$$

where:  $F_{pl}$  = required bending stress

$R_1$  = adjustment factor for partial cure. Ratio of partially-cured joint tension strength to fully-cured joint tension strength

$QSL$  = qualification stress level for end joints in tension lamination

The required force for the proof load shall be determined based on the loading and support conditions using the principles of solid mechanics.

#### **T118.5. DETERMINATION OF $R_1$ .**

The ratio of partially-cured end joint tension strength to fully-cured end joint tension strength ( $R_1$ ) shall be determined for each adhesive-species-treatment combination and QSL for which the bending proof load will be used.

For fully cured end joints,  $R_1$  is equal to 1.0.

$R_1$  is permitted to be taken as 0.67 provided that the proof load is applied within one minute after the end joint leaves the RF tunnel. Alternatively, plants are permitted to determine  $R_1$  using the procedure presented in T118.5.1.

If the proof load is applied after one minute from the time the end joint leaves the RF tunnel, but before the time for full cure,  $R_1$  shall be determined as presented in T118.5.1.

##### **T118.5.1. Determination of $R_1$ by Test.**

- (a) End joints shall be produced from 2x6 lumber according to documented plant procedures. There shall be no knots within 1 ft. of each end joint. The specific gravity for each test specimen shall be not less than the average for the species or more than 0.08 above the average. The moisture content of the test specimens shall be within 5 percentage points of each other. The maximum moisture content of an individual specimen shall not exceed 15%. Curing shall be in accordance with documented plant procedures. When the RF tunnel curing system is used, the tunnel shall be fully loaded for its entire length and the test end joints shall not be allowed to stop in the tunnel.
- (b) Sixty end joints shall be manufactured at the same time and numbered consecutively. These joints shall be grouped in 2 samples of 30 specimens each by putting the odd-numbered joints in one sample and the even numbered in the other.
- (c) One sample shall be tested to failure in tension in the partially-cured condition. The time of testing after the radio frequency or other curing cycle has been completed shall be as near as possible to the time interval that normally occurs between curing and proof loading. Testing shall be performed in accordance with AITC Test T119, except that the rate of loading shall be such that failure is obtained within 10 seconds after application of load.

- (d) The other sample shall be allowed to cure for at least 24 hours. These joints shall be tested in tension by AITC Test T119. The end joint strength 5% tolerance limit with 75% confidence shall equal or exceed 1.67 times the specified QSL.
- (e) The ratio,  $R_1$ , shall be determined by dividing the average tension strength of the partially-cured end joints and the average tension strength of the fully-cured end joints.

## **T118.6. QUALIFICATION PROCEDURE.**

### **T118.6.1. Qualification Sample.**

One sample of end joints shall be manufactured and proof loaded according to the established plant procedures. A sufficient number of end joints shall be manufactured, so that a minimum of 30 end joints pass the proof-load test.

### **T118.6.2. Tension Tests.**

Laminations passing the proof load (not rejected) shall be surfaced to the finished size typical of production and allowed to cure completely. The fully-cured laminations shall be tested in tension in accordance with AITC Test T119.

The 5% tolerance limit with 75% confidence of the tensile strength of the proof loaded end joints shall equal or exceed 1.67 times the required QSL.

## **T118.7. INTERPRETATION OF RESULTS.**

Proof-loaded end joints meet the requirements of this standard when:

- (a) The proof load level has been determined in accordance with the requirements herein.
- (b) The 5% tolerance limit with 75% confidence on tension strength of proof-loaded end joints equals or exceeds 1.67 times the required QSL.
- (c) The manufacture and testing for qualification have been witnessed by the AITC Inspection Bureau.
- (d) The system has been shown to reject any lamination when the indicated modulus of elasticity is below 57% of the modulus of elasticity of the grade being proof loaded. Modulus of elasticity is based on long span E.
- (e) The system has been shown to reject clearly defective end joints, such as those manufactured without adhesive, with partial adhesive, or with improperly machined fingers.
- (f) Documented procedures are in place to ensure all rejected laminations are clearly marked on one edge and one face at the point causing rejection.
- (g) Documented procedures are in place to ensure all rejected laminations are removed from production and are not used as tension laminations in a member.
- (h) The Procedures Manual documents that the following laminations are to be proof loaded:
  - 1. All of the outer tension zone(s) in bending members (as described in the laminating specifications), but not less than 10% of the total depth of the member for each tension zone.
  - 2. All of the laminations in a tension member loaded to 75% or more of the design value in tension and
  - 3. The outer 10% of the laminations on each side of a tension member loaded to less than 75% of the design value in tension.
- (i) All proof-loaded laminations are marked on an edge at regular intervals.

The proof loading process has been approved by the AITC Inspection Bureau and documented in Plant Procedures and Quality Control Manuals.

**T118.8. REPORT.**

Records shall include the certification data gathered, calibration information, documented procedures, and corrective action procedures.

Daily quality control records shall document the number of rejected end joints, the disposition of rejected joints, and any corrective actions taken.



# American Institute of Timber Construction

7012 South Revere Parkway • Suite 140 • Centennial, CO 80112  
Phone: 303/792-9559 Fax: 303/792-0669

## AITC Test T119-2007

### Full Size End Joint Tension Test

Adopted as Recommendations, April 23, 2007

Copyright 2007 by

American Institute of Timber Construction

#### T119.1. SCOPE.

This test provides procedures and requirements for testing full size end joints in tension. This test is used for end joint qualification tests, proof loading qualification tests, daily quality control, and other purposes where the strength of full size end joints must be evaluated.

#### T119.2. SUMMARY OF METHOD.

End joint specimens are taken at random from the available supply and pulled in tension to failure.

#### T119.3. APPARATUS.

- (a) Test machine – The test machine shall have a mechanism for applying and accurately measuring an axial tension load at a controlled rate to full-size laminations.
- (b) Grips – The test machine shall have grips or clamping devices to transmit the tensile load from the testing machine to the test specimen such that specimen damage due to clamping is minimized and that slippage is prevented.
- (c) Distance between grips – The grips shall be spaced not closer than two ft. apart.
- (d) Load control - The test machine shall have a means to control the loading, such that load is applied at a constant rate and failure is produced in 3-5 minutes.

When possible, tension testing equipment shall be capable of testing the widest single piece lamination used by the plant up to and including a nominal 2x12.

#### T119.4. MATERIALS.

- (a) Specimens shall be representative of production.
- (b) Specimens for testing are permitted to be surfaced to the dimensions typical of laminations in the finished product.
- (c) Samples shall be taken at random for the grade being tested or as required by the test program.

#### T119.5. PROCEDURE.

- (a) The net width and thickness at the end joint shall be recorded to the nearest 0.01 in. for each specimen.
- (b) The test specimen shall be centered between the grips.
- (c) Load shall be applied to the specimen at a constant rate until failure.

Note: If possible, load should be applied at a constant rate of increase. Either load or displacement control is acceptable. It is recognized that when testing in production facilities, precise control of the rate of loading



may not be possible. Load should therefore be applied at a rate that is as close to constant as is practical. Sudden increases in load should be avoided. Load should be applied at such a rate as to induce failure between 3-5 minutes.

(d) The strength of the lamination at the end joint and the failure mode shall be recorded.

**T119.6. REPORT.**

Daily records shall include at a minimum, all test data (date, operator, lumber size, time to failure, failure mode, etc.), corrective actions taken, re-testing and any other pertinent information dealing with the quality control of end joints.



# American Institute of Timber Construction

7012 South Revere Parkway • Suite 140 • Centennial, CO 80112  
Phone: 303/792-9559 Fax: 303/792-0669

## AITC Test T121-2007

### Tension Proof Loading for End Joints

Adopted as Recommendations, April 23, 2007

Copyright 2007 by

American Institute of Timber Construction

#### **T121.1. SCOPE.**

The tension proof loading quality control test is intended to ensure the strength of end joints by testing at a stress level high enough to detect and reject low-strength end joints in tension laminations, but low enough to avoid causing damage to laminations passing the test. Proof loading may be performed on fully-cured or partially-cured end joints. This system provides greater structural reliability by the rejection of low-strength end joints.

#### **T121.2. APPARATUS.**

##### **T121.2.1. Proof Loader.**

Any machine or device that can grip the lamination without damage and apply a predetermined tension load to the end joint or joints shall be acceptable.

- (a) The loading device shall be capable of applying different loads for use with different lumber sizes and stress levels.
- (b) The proof-loader shall have the capacity and all of the necessary controls, gauges, etc. to permit proof loading of all widths and thicknesses intended for production.

##### **T121.2.2. Failure Indicators.**

The proof loader shall be capable of detecting breaks or damage to low-strength end joints. The following devices are required.

- (a) An audible warning device which sounds an alarm when a failure occurs.
- (b) A device that applies a mark on one edge *and* one face at the end joint or point where the failure has occurred.

##### **T121.2.3. Grips.**

The proof loader shall have grips or clamping devices capable of transferring the tension load from the machine to the lamination without damage.

##### **T121.2.4. Marking Device.**

A device that marks at least one edge at regular intervals along the proof-loaded lamination shall be required if proof loading will be used to justify reduced end joint spacing intervals.

### **T121.3. CALIBRATION.**

At a minimum, all measuring equipment shall be calibrated by the AITC Inspection Bureau prior to initial use and annually. The force exerted by the proof loader shall be calibrated by the use of a proving ring, tension link, or load cell. A calibration chart shall be prepared.

### **T121.4. PROOF LOAD LEVEL.**

The required tension stress induced by the proof load shall be determined from the following equation:

$$F_{pl} = 1.5R_1(QSL) \geq 0.9(QSL)$$

where:  $F_{pl}$  = required tension stress

$R_1$  = adjustment factor for partial cure. Ratio of partially-cured joint strength to fully-cured joint strength

$QSL$  = qualification stress level for end joints in tension lamination

### **T121.5. DETERMINATION OF $R_1$ .**

The ratio of partially-cured end joint tension strength to fully-cured end joint tension strength ( $R_1$ ) shall be determined for each adhesive-species-treatment combination and QSL for which the bending proof load will be used.

For fully cured end joints,  $R_1$  is equal to 1.0.

$R_1$  is permitted to be taken as 0.67 provided that the proof load is applied within one minute after the end joint leaves the RF tunnel. Alternatively, plants are permitted to determine  $R_1$  using the procedure presented in T121.5.1.

If the proof load is applied after one minute from the time the end joint leaves the RF tunnel, but before the time for full cure,  $R_1$  shall be determined as presented in T121.5.1:

#### **T121.5.1. Determination of $R_1$ by Test.**

- (a) End joints shall be produced from 2x6 lumber according to documented plant procedures. There shall be no knots within 1 ft. of each end joint. The specific gravity for each test specimen shall be not less than the average for the species or more than 0.08 above the average. The moisture content of the test specimens shall be within 5 percentage points of each other. The maximum moisture content of an individual specimen shall not exceed 15%. Curing shall be in accordance with documented plant procedures. When the RF tunnel curing system is used, the tunnel shall be fully loaded for its entire length and the test end joints shall not be allowed to stop in the tunnel.
- (b) Sixty end joints shall be manufactured at the same time and numbered consecutively. These joints shall be grouped in 2 samples of 30 specimens each by putting the odd-numbered joints in one sample and the even numbered in the other.
- (c) One sample shall be tested to failure in tension in the partially-cured condition. The time of testing after the radio frequency or other curing cycle has been completed shall be as near as possible to the time interval that normally occurs between curing and proof loading. Testing shall be performed in accordance with AITC Test T119, except that the rate of loading shall be such that failure is obtained within 10 seconds after application of load.
- (d) The other sample shall be allowed to cure for at least 24 hours. These joints shall be tested in tension by AITC Test T119. The end joint strength 5% tolerance limit with 75% confidence shall equal or exceed 1.67 times the specified QSL.

- (e) The ratio,  $R_1$ , shall be determined by dividing the average tension strength of the partially-cured end joints and the average tension strength of the fully-cured end joints.

#### **T121.6. QUALIFICATION PROCEDURE.**

##### **T121.6.1. Qualification Sample.**

One sample of end joints shall be manufactured and proof loaded according to the established plant procedures. A sufficient number of end joints shall be manufactured, so that a minimum of 30 end joints pass the proof-load test.

##### **T121.6.2. Tension Tests.**

Laminations passing the proof load (not rejected) shall be surfaced to the finished size typical of production and allowed to cure completely. The fully-cured laminations shall be tested in tension in accordance with AITC Test T119. The 5% tolerance limit with 75% confidence of the tensile strength of the proof loaded end joints shall equal or exceed 1.67 times the required QSL.

#### **T121.7. INTERPRETATION OF RESULTS.**

Proof loaded end joints meet the requirements of this standard when:

- (a) The proof load level has been determined in accordance with the requirements herein.
- (b) The 5% tolerance limit with 75% confidence on tension strength of proof-loaded end joints equals or exceeds 1.67 times the required QSL.
- (c) The manufacturing and testing for qualification have been witnessed by the AITC Inspection Bureau.
- (d) The system has been shown to reject any lamination which breaks or exhibits distress during tension proof loading.
- (e) The system has been shown to reject clearly defective end joints, such as those manufactured without adhesive, with partial adhesive, or with improperly machined fingers.
- (f) All rejected laminations are clearly marked on one edge and one face at the point causing rejection.
- (g) Documented procedures are in place to ensure all rejected laminations are removed from production and are not used as tension laminations in a member
- (h) The Procedures Manual documents that the following laminations are to be proof loaded:
  1. All of the outer tension zone(s) (as described in the laminating specifications), but not less than 10% of the total depth of the member for each zone,
  2. All of the laminations in a tension member loaded to 75% or more of the design value in tension and
  3. The outer 10% of the laminations on each side of a tension member loaded to less than 75% of the design value in tension.
- (i) All proof loaded laminations are marked on an edge at regular intervals.
- (j) The proof loading process has been approved by the AITC Inspection Bureau and documented in Plant Procedures and Quality Control Manuals.

#### **T121.8. REPORT.**

Records shall include the certification data gathered, calibration information, documented procedures, and corrective action procedures.

Daily quality control records shall document the number of rejected end joints, the disposition of rejected joints, and any corrective actions taken.



# American Institute of Timber Construction

7012 South Revere Parkway • Suite 140 • Centennial, CO 80112  
Phone: 303/792-9559 Fax: 303/792-0669

## AITC Test T122-2007

### Mix Ratio Check for Automatic Adhesive Mixing Machines

Adopted as Recommendations, April 23, 2007

Copyright 2007 by

American Institute of Timber Construction

#### **T122.1. SCOPE.**

This test procedure shall be used to verify the hardener (powder or liquid slurry) to resin (liquid) mix ratio in automatic adhesive mixing systems. The ratios may be verified by weight or volume depending on the design of the automatic mixing machine and the adhesive requirements. Machines of this type typically regulate the proportion of powder or liquid hardener that is mixed with the resin as it moves from a hopper or storage container to the mixing chamber located at the discharge nozzle.

#### **T122.2. SUMMARY OF METHODS.**

Each component of the two-part mix is metered separately for a specified period of time. The time interval may vary depending on the machine designs but should be sufficient to overcome measurement errors with available scales (30-60 seconds). The adhesive component quantities are determined by weight or volume, as appropriate. The adhesive component mix ratio is compared to the adhesive manufacturer's recommendations for variation tolerances.

#### **T122.3. APPARATUS.**

One or two containers, a scale accurate to 0.1 lb. and a timer such as a stop watch. The container(s) must be large enough to hold the appropriate discharge from the automatic mixing machine.

#### **T122.4. PRECAUTIONS.**

- (a) Powder hardeners must be prevented from compacting in the hopper or in the feed tube through the use of a vibrator, or other suitable means.
- (b) Uniformity of flow for both the resin and hardener must be maintained if the mix proportions are to be accurately determined. Restricting the flow to obtain the desired spread rate, or to measure separate flow rates of each component may influence the mixed proportions due to the effects of back pressure in the system. Measurement of the mixed adhesive weight should be determined for maximum and minimum flow rates to determine the sensitivity of the flow rate to these external factors.

#### **T122.5. SAMPLING.**

Sampling frequency may vary depending on the reliability of the automatic mix ratio shut off sensing device. Under normal operation, a ratio check prior to the face bonding operation is sufficient on a daily basis. If inconsistencies are detected, ratio checks shall be made every 30-60 minutes during the bonding operation, or until the desired measurement consistency is established.

## **T122.6. PROCEDURES.**

- (a) The resin and hardener source containers shall be adequately filled to maintain full flow through the system during the sampling period. Warning devices designed to signal low levels of the resin and/or hardener shall be checked for operation at this time.
- (b) With the machine in normal operating mode, a sample of the resin and a sample of the hardener shall be collected as specified by the machine manufacturer's operating instructions. The containers shall be inserted into the material flow and removed from it without adjusting the flow rate during this process. Samples of the individual adhesive components shall be collected using the same back pressure as that generated at the mixer. A stop watch (or equivalent) should be used to accurately measure the duration of time involved. The quantity (weight or volume, as appropriate) of each component collected shall be measured to the nearest 0.1 lb. or fluid ounce
- (c) In a similar manner, samples of the mixed adhesive shall be collected for both maximum and minimum discharge rates.

## **T122.7. INTERPRETATION OF RESULTS.**

The ratio of the resin to hardener shall be compared with the adhesive manufacturer's recommendations for acceptable tolerances. If the measured ratio is not within the specified limits of variability permitted, corrective actions shall be taken and the test shall be repeated. The mixed weight shall be compared with the predicted component weight total for the time it was dispensed.

Imbalance in the mix ratios may be related to one or more of the following factors:

- (a) Malfunction of line pressure gauges.
- (b) Leakage of pump seals.
- (c) Dirty system filters.
- (d) Chunks in slurry component due to poor mixing in source container.

### **T122.7.1. Liquid/Powder Systems.**

In addition to the above factors, the following factors may cause imbalance in the liquid powder system:

- (a) Compacting of the powder hardener resulting in a "tunneling" effect at the feed screw.
- (b) Dampness in the system, such as in the hopper, or on the sensing cone (where used as a metering device).
- (c) Blockage of the hardener supply conduit from small pieces of debris such as paper from sacks or lumps caused by wet hardener.

### **T122.7.2. Liquid/Liquid System.**

Problems in the liquid/liquid system may also be caused by back pressure in source lines due to malfunction of feed pumps due to wear (abrasive or corrosive action).

## **T122.8. REPORT.**

The data recorded for this test shall include the weight and/or volume measurements, the mix ratios, and the times of day that the mix ratios were checked as well as corrective actions and subsequent testing.



# American Institute of Timber Construction

7012 South Revere Parkway • Suite 140 • Centennial, CO 80112

Phone: 303/792-9559 Fax: 303/792-0669

## AITC Test T123-2007

### Sampling, Testing and Data Analysis to Determine Tensile Properties of Lumber

Adopted as Recommendations, April 23, 2007

Copyright 2007 by

American Institute of Timber Construction

#### **T123.1. SCOPE.**

This test covers requirements for sampling, testing, and data analysis of candidate lumber to be qualified for use as laminations for structural glued laminated timber.

#### **T123.2. SUMMARY OF METHOD.**

This test is similar to AITC Test T119 except that AITC Test T119 is used for testing end joints with a minimum 2 ft. gauge length and AITC Test T123 is used for testing lumber over a larger gauge length. This test procedure also covers methods of sampling and analysis of the test data.

#### **T123.3. SAMPLING.**

##### **T123.3.1. Method.**

- (a) Sampling and testing shall be witnessed by the AITC Inspection Bureau.
- (b) The sample shall be representative of the candidate lumber grade.
  1. If there is candidate lumber in inventory well in excess of the required sample size, the sample shall be selected using the principle of selection of approximately equal amounts from 3 different periods of production. For example: Eight units of candidate lumber are in inventory. One unit should be selected from the oldest units, two from the middle and one from the latest units placed in inventory.
  2. Specimens shall be selected from units of production to assure random selection or to maintain serial order. When it is determined that serial selection will provide the best representation of candidate lumber properties, the top layer of each unit of candidate lumber shall be discarded, then the required specimens shall be selected in serial order. When it is determined that a random selection will best represent the candidate lumber properties, a number shall be assigned to each piece and specimens from each sample unit shall be selected using a random number generator.
  3. If candidate lumber is not in inventory in sufficient quantity to assure a representative sample, selection shall be made from production with procedures to assure the required representative sample. Examples: when approximately 10% of production is candidate lumber, the sampling procedure used may accept each piece as it occurs on the grading chain except that it will accept no pieces not separated by non-candidate lumber; or, when 50% or less of the production is candidate lumber, 25% of the required specimens may be selected in serial order as they occur on the grading chain, with a similar quantity allowed to pass before selecting the second batch of 25%, etc., until the required sample is selected.

- (c) A sample of each size and grade category to be qualified is generally required, however, 2x6 lumber is permitted to be sampled to qualify both 2x6 and 2x4 lumber, and 2x10 lumber is permitted to be tested to qualify 2x8, 2x10 and 2x12 sizes. Qualification of 2 in. nominal thickness lumber will also qualify 1 in. nominal thickness lumber of the same width and grade.
- (d) Each specimen shall be of such length to permit tensile testing with a minimum 8 ft. gauge length. End joints are permitted to be used to create test specimens from shorter pieces. For 8 ft. or longer pieces, end joints can be located inside the grips.

**T123.3.2. Size.**

- (a) Sample size shall be determined by the requirements of the test program.
  1. The choice of sample size must anticipate the statistical analysis to be employed as well as practical sampling considerations.
  2. If a nonparametric analysis of the test data is to be used, Table T123-1 will establish the order statistic that determines the fifth percentile estimate as a function of the sample size. Consequently, Table T123-1 is one source of sample size estimation.
  3. If parametric distributions are used to estimate the fifth percentile, the procedures of ASTM D 2915 may be used to estimate the necessary sample size.
- (b) Three hundred lineal feet shall be the minimum test sample between the tension grips (sum of individual specimen gauge lengths).

**T123.3.3. Specimen Preparation.**

- (a) *Width* – Specimens are permitted to be tested at the standard dressed width or after surfacing to the net finished beam width.
- (b) *Thickness* – Specimens are permitted be surfaced to a thickness representing finished laminations. If several production thicknesses are used, the thickness of the test specimens shall be the maximum thickness used in production. This will qualify thinner pieces of the same nominal thickness.
- (c) *Moisture Content* – The average moisture content of the sample shall be from 8 to 12% at the time of testing.
- (d) *Modulus of Elasticity* – The long-span modulus of elasticity (E) of *all* specimens shall be determined in accordance with AITC Test T116.
- (e) *Specific Gravity* – The specific gravity based on oven dry weight and volume at 12% moisture content for all specimens shall be determined by the procedure included in ASTM D 2395. Specimen weight, size and moisture content shall be an acceptable method of determining the specific gravity. The specific gravity calculation shall be as follows:

$$SG = \frac{27.68 \cdot W}{\left(l + \frac{m}{100}\right) \cdot b \cdot t}$$

where:

- $W$  = weight of specimen (lb.)
- $m$  = moisture content (%)
- $l$  = length of specimen (in.)



- $b =$  width of specimen (in.)  
 $t =$  thickness of specimen (in.)

#### **T123.4. PROCEDURE.**

##### **T123.4.1. General.**

Three options are available for testing the sample to determine a 5% tolerance limit with 75% confidence:

- (a) Option 1: The entire sample shall be tested to destruction, and determine the 5% tolerance limit with 75% confidence using an appropriate statistical procedure.
- (b) Option 2: Each specimen in the sample shall be loaded to the required fifth percentile for the target grade. If any specimen fails, the order statistic listed in Table T123-1 shall equal or exceed the required 5% tolerance limit with 75% confidence for the grade.
- (c) Option 3: The Warren-Glick procedure shall be used.
  1. It is recommended that the specimens in the sample be ordered by visual quality, density, E-value, and/or other parameter(s) to rank the pieces by expected strength.
  2. The number (rank),  $n$ , of the order statistic for estimating the 5% tolerance limit with 75% confidence shall be determined using Table T123-1 based on the sample size.
  3. The first  $n$  pieces with the lowest expected strength shall be tested to failure.
  4. Each subsequent specimen shall be subjected to the load corresponding to the  $n^{\text{th}}$  smallest value of all previously failed specimens. (With each subsequent failure, the proof load is reduced to the  $n^{\text{th}}$  smallest value, where  $n$  is the number (rank) of the desired order statistic.)
  5. After all specimens in the sample are tested, the  $n^{\text{th}}$  smallest value represents the 5% tolerance limit with 75% confidence.

##### **T123.4.2. Tension Testing.**

- (a) Specimens shall be tested in tension following procedures in ASTM D 198 except that faster loads are permitted such that an average strength specimen will not fail in less than 2 minutes and a minimum strength specimen will not fail in less than one minute.
- (b) A constant rate of loading or displacement shall be maintained throughout the test.
- (c) A minimum test span (between grips) of 8 ft. shall be maintained.
- (d) Pieces shall be centered in the test span.

#### **T123.5. TEST REPORT.**

The test report shall contain the following information on each specimen:

- (a) Long-span modulus of elasticity
- (b) Moisture content
- (c) Specific gravity
- (d) Cross-sectional dimensions at mid-span
- (e) Tensile strength (of failed specimens)
- (f) Species density and other visual description of the sample
- (g) Stress level at which tested

A complete description of the sampling, testing and analysis procedures shall be reported with specific reference to the respective paragraph requirements.

**Table T123-1**

**SAMPLE SIZE AND ORDER STATISTIC FOR ESTIMATING THE 5% NONPARAMETRIC  
TOLERANCE LIMIT WITH 75% CONFIDENCE**

Sample Size	Order Statistic <sup>a</sup>
53	2
78	3
102	4
125	5
148	6
170	7
193	8
215	9
237	10
259	11
281	12
303	13
325	14
347	15

<sup>a</sup> The rank of the ordered observations, beginning with the smallest.



# American Institute of Timber Construction

7012 South Revere Parkway • Suite 140 • Centennial, CO 80112  
Phone: 303/792-9559 Fax: 303/792-0669

## AITC Test T124-2007

### Reinspection or Testing of Individual Lots of E-Rated Lumber for Conformance to Specifications

Adopted as Recommendations, April 23, 2007

Copyright 2007 by

American Institute of Timber Construction

#### **T124.1. SCOPE.**

This test covers requirements for sampling, testing, and data analysis of E-rated lumber for reinspection purposes. These requirements are used to determine conformance of a given lot of lumber of a single E-rated grade to the specifications of that grade.

#### **T124.2. ISOLATION OF LUMBER FOR REINSPECTION.**

- (a) The lumber to be reinspected shall be clearly identified by all concerned parties. Criteria for identification include origin, shipment, size, species, grades and any other identifying features.
- (b) For purposes of analysis and acceptance the lumber shall be divided into reinspection lots consisting of one size (thickness and width), one species or species mix and one E-rated grade.
- (c) The test results of each reinspection lot shall be subject to analysis for acceptance on an individual lot basis.

#### **T124.3. APPARATUS AND PROCEDURE.**

The procedure and equipment for AITC Test T116 shall be used for this test.

#### **T124.4. SAMPLING.**

- (a) *Reinspection Lots of 125 Pieces or More:* For reinspection lots containing 125 or more pieces, the test sample shall number 125 pieces selected serially from each reinspection lot.
- (b) *Reinspection Lots of Less Than 125 Pieces:* For reinspection lots containing less than 125 pieces, the entire lot shall be tested.

#### **T124.5. DATA ANALYSIS.**

- (a) The sample mean long span E shall be calculated.
- (b) The number of pieces with long span E values less than the 5th percentile long span E value specified for the grade shall be determined.
- (c) A reinspection lot shall be accepted if conditions for both the mean and 5th percentile are met as follows:
  1. The upper bound of the 95% confidence interval of the sample mean long-span E shall equal or exceed the assigned E-value for the grade. Alternatively, the values in Table T124-1 are permitted to be used if all affected parties agree. A mean long span E equal to or greater than the E-value shown in Table T124-1 for the sample size and grade of the reinspection lot. If

the lot size is different than the number shown in the table, the next smaller lot size is permitted to be used to determine the acceptance criterion.

- The lot shall not have more pieces below the grade 5th percentile than the number permitted in Table T124-2 based on lot size.

**Table T124-1.** Required average long-span *E* based on grade and lot size.

$E_{\text{grade}}$	n										
	120	60	40	30	25	20	18	16	14	12	10
<b>2.6</b>	2.56	2.55	2.53	2.52	2.51	2.50	2.49	2.49	2.48	2.46	2.45
<b>2.5</b>	2.46	2.45	2.43	2.42	2.41	2.40	2.40	2.39	2.38	2.37	2.35
<b>2.4</b>	2.36	2.35	2.33	2.32	2.31	2.30	2.30	2.29	2.28	2.27	2.25
<b>2.3</b>	2.26	2.25	2.23	2.22	2.22	2.20	2.20	2.19	2.18	2.17	2.15
<b>2.2</b>	2.16	2.15	2.14	2.12	2.12	2.11	2.10	2.09	2.08	2.07	2.06
<b>2.1</b>	2.06	2.05	2.04	2.03	2.02	2.01	2.00	1.99	1.99	1.97	1.96
<b>2</b>	1.96	1.95	1.94	1.93	1.92	1.91	1.90	1.90	1.89	1.88	1.86
<b>1.9</b>	1.86	1.85	1.84	1.83	1.82	1.81	1.80	1.80	1.79	1.78	1.76
<b>1.8</b>	1.77	1.75	1.74	1.73	1.72	1.71	1.71	1.70	1.69	1.68	1.66
<b>1.7</b>	1.67	1.65	1.64	1.63	1.62	1.61	1.61	1.60	1.59	1.58	1.57
<b>1.6</b>	1.57	1.55	1.54	1.53	1.52	1.51	1.51	1.50	1.49	1.48	1.47
<b>1.5</b>	1.47	1.45	1.44	1.43	1.42	1.41	1.41	1.40	1.39	1.38	1.37
<b>1.4</b>	1.37	1.35	1.34	1.33	1.33	1.32	1.31	1.30	1.30	1.29	1.27
<b>1.3</b>	1.27	1.25	1.24	1.23	1.23	1.22	1.21	1.21	1.20	1.19	1.17

**Table T124-2.** Lot acceptance criterion for number of pieces below required 5th percentile.

Lot Size	Accept	Reject
1-5	0	1 or more
6-11	1 or less	2 or more
12-21	2 or less	3 or more
22-32	3 or less	4 or more
33-45	4 or less	5 or more
46-58	5 or less	6 or more
59-72	6 or less	7 or more
73-86	7 or less	8 or more
87-100	8 or less	9 or more
100-114	9 or less	10 or more
115-125	10 or less	11 or more

## **T124.6. DISPOSITION OF REJECTED LOTS.**

The lumber in lots rejected by this test procedure shall not be used as graded.

### **T124.6.1. Regrade.**

The lumber shall be permitted to be regraded by testing all of the pieces in the lot in accord with the long-span E testing procedures of AITC Test T116 and eliminating low E pieces from the lot so that the specifications for mean and lower 5th percentile E values of the E-rated grade are met. If the lumber is regraded by commercial testing devices other than a long-span E measuring device, conformance to grade specifications shall be verified by this test.

### **T124.6.2. Assign a Lower Grade Level.**

The lumber shall be permitted to be used at a lower E-rated grade level for which the lot was qualified by the test results.

## **T124.7. REPORT.**

Results of the reinspection shall be compiled in complete, concise format for all parties involved. The report shall describe:

- (a) The sample population and all inspection lots
- (b) The sampling plan
- (c) Testing and reinspection results for each inspection lot
- (d) The disposition of non-conforming lots.